

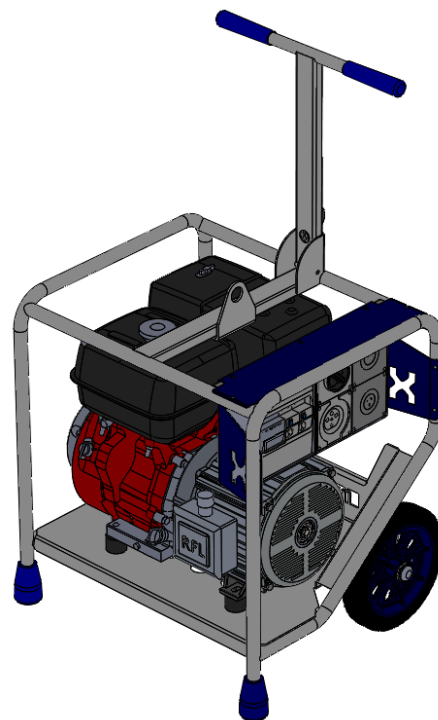

10kVA Generator

- GEN-10P
- 2x15A Outlets
- 2x15A + 1x20A (or 32A) 3P Outlets



OPERATOR'S MANUAL

Rev0919

Table of Contents

INTRODUCTION	1
DISCLAIMER.....	1
ABOUT THIS MANUAL.....	2
KEY TERMS.....	2
PRODUCT INFORMATION	3
SAFETY INFORMATION	3
SAFETY DECALS	6
PRODUCT SPECIFICATIONS	8
FEATURES.....	8
OVERALL MACHINE DIMENSIONS.....	9
ALTERNATOR SPECIFICATIONS	9
OPERATION	10
BEFORE USE	10
OPERATING GENERATOR	11
STARTING THE ENGINE	12
CONNECTING ELECTRICAL DEVICES.....	12
SHUTTING DOWN THE GENERATOR.....	12
GENERAL RECOMMENDATIONS:	13
STORAGE	14
LIMITED WARRANTY.....	15
WARRANTY EXCLUSIONS	16
OWNER’S RESPONSIBILITY UNDER LIMITED WARRANTY:	16
CONTACT INFORMATION	17
APPENDICES.....	19
APPENDIX A- WIRING CIRCUIT DIAGRAM (2x15A)	20
APPENDIX B- WIRING CIRCUIT DIAGRAM (2x15A + 1x20A 3P).....	21
APPENDIX C- RISK ASSESSMENT	22

INTRODUCTION

Thank you for purchasing a MAKINEX product.

This manual provides information and procedures to safely operate and maintain the **GEN-10P** Generator. For your own safety and protection from injury, carefully read, understand and observe the safety instructions described in this manual.

Keep this manual or a copy of it with the machine. If you lose this manual or need an additional copy, please contact MAKINEX. This machine is designed and built with user safety in mind; however, it can present hazards if improperly operated and serviced. Please follow the operating instructions carefully. If there are any questions regarding operating or servicing of this machine, please contact MAKINEX.

All rights, especially copying and distribution rights are reserved.

Copyright 2019 by MAKINEX

No part of this publication may be reproduced in any form or by any means, electronic or mechanical, including photocopying, without express written permission from MAKINEX

Any type of reproduction or distribution not authorised MAKINEX represents an infringement of valid copyrights and will be persecuted. We expressly reserve the right to make technical modifications, even without due notice, which aim at improving our machines or their safety standards.

DISCLAIMER

MAKINEX and its affiliates take no responsibility for any damage, injury or death resulting from the incorrect or unsafe use of this product. Use of this product should be undertaken by competent persons only. It is the operator's responsibility to ensure that the following safety procedures are followed. If you are unsure, do not operate this product.

Record the model and serial numbers as well as date and place of purchase for future reference. Have this information available when ordering parts and when making technical or warranty inquiries

MAKINEX SUPPORT

Refer to contact details on pg. 17

MODEL NO.

GEN-10P

SERIAL NO.

DATE OF PURCHASE

PURCHASE LOCATION

ABOUT THIS MANUAL

This manual uses the following symbols to help differentiate between different kinds of information. The safety symbol is used with a key word to alert you to potential hazards in operating and owning power equipment. Follow all safety messages to avoid or reduce the risk of serious injury or death.

KEY TERMS



READ CAREFULLY

READ CAREFULLY – refers to *important information* that should be paid careful attention.



CAUTION

CAUTION - indicates a potential hazardous situation which, if not avoided, *may* result in minor or moderate injury



WARNING

WARNING – indicates a potentially hazardous situation which, if not avoided, *could* result in death or serious injury



DANGER

DANGER – indicates a imminently hazardous situation which, if not avoided, *will* result in death or serious injury



PROHIBITED

PROHIBITED – identifies actions that *should never* be carried out by anyone interacting with the machine.

PRODUCT INFORMATION

SAFETY INFORMATION



Read this manual **thoroughly** before operating your generator. Failure to follow instructions could result in serious injury or death



MAKINEX GEN-10P Generator designed for professional operators only, instruct operators in care and use of the machine before use!



GENERAL SAFETY PRECAUTIONS

- **ALWAYS** use in a well-ventilated area.
- **ALWAYS** ensure the applied load does not exceed the generators rating. Overloading the generator is dangerous and could cause serious damage.
- **ALWAYS** disconnect the generator when carrying out any maintenance.
- **ALWAYS** ensure the generator reaches operating speed before connecting a load.
- **ALWAYS** start the engine BEFORE connecting any appliances to the output receptacles.
- **ALWAYS** test the RCBO's before use.
- **ALWAYS** check the generator for damage before use.
- **ALWAYS** keep well clear of all moving parts on the generator at all times.
- **NEVER** allow children or animals near the generator.
- **NEVER** connect to a commercial or mains power supply, or any other electrical source.
- **NEVER** allow the generator to run out of fuel when a load is connected.
- **NEVER** alter or tamper with the internal wiring of the generator.
- **NEVER** climb or stand on the generator as dents may cause overheating of the acoustic lining.

- **NEVER** touch any part of the engine, alternator or exhaust when the generator is in use as these get hot and could burn.

 DANGER	RISK OF EXPLOSION OR FIRE
	<ul style="list-style-type: none"> • Fuel and its vapours are extremely flammable and explosive • Fire or explosion can cause severe burns or death

- **ALWAYS** switch the engine OFF when refuelling.
- **ALWAYS** refuel away from any source of heat.
- **ALWAYS** refuel in a well-ventilated area.
- **NEVER** overfill fill the tank, fill to the level specified.
- **NEVER** smoke whilst refuelling and avoid smoking or using a naked flame near the generator.
- **NEVER** start the engine if there is a fuel spill. Any spillage must be wiped clean and the generator allowed to dry before attempting to start the engine.

 DANGER	RISK OF BREATHING
	<ul style="list-style-type: none"> • Running engine gives off Carbon Monoxide, an odourless, colourless, poisonous gas. • Breathing Carbon Monoxide can cause nausea, fainting or death. • Some chemicals or detergents may be harmful if inhaled or ingested, causing severe nausea, fainting or poisoning.

WARNING: EXHAUST FUMES CAN BE FATAL.

- **ALWAYS** ensure that there is adequate ventilation when using the generator.
- **ALWAYS** position the generator so that the exhaust is pointing away from people or animals.
- **NEVER** use the generator indoors or in an enclosed area. (i.e. in ware house, tunnel, well or a hold).



WARNING

RISK OF ELECTRICAL SHOCK

- Risk of electrocution.

- **ALWAYS** test the RCBO's before use.
- **ALWAYS** store the generator undercover when not in use and away from damp or wet conditions.
- **NEVER** use the generator outdoor when it is raining or snowing or in wet or damp conditions.
- **NEVER** use water or any other liquids to clean the unit while it is running.



DANGER

RISK OF HOT SURFACES

- Contact with hot surfaces, such as engines exhaust components, could result in serious burn.

- During operation, touch only the control surfaces of generator. Keep children away from the generator at all times. They may not be able to recognise the hazards of this product.



WARNING

POSITIONING THE GENERATOR FOR USE

- **ALWAYS** leave at least a 1 metre gap between the generator and any surrounding building or structure.
- **ALWAYS** ensure the generator is on a solid, flat surface.
- **ALWAYS** ensure the surrounding area is free from any material that could burn or be damaged by heat.
- **NEVER** move or tilt the generator whilst it is switched on.
- **NEVER** cover or enclose the generator whilst it is in use.
- Be aware of the weight of the generator, do not attempt to lift or move the generator without the assistance of other personnel or suitable lifting equipment.

SAFETY DECALS

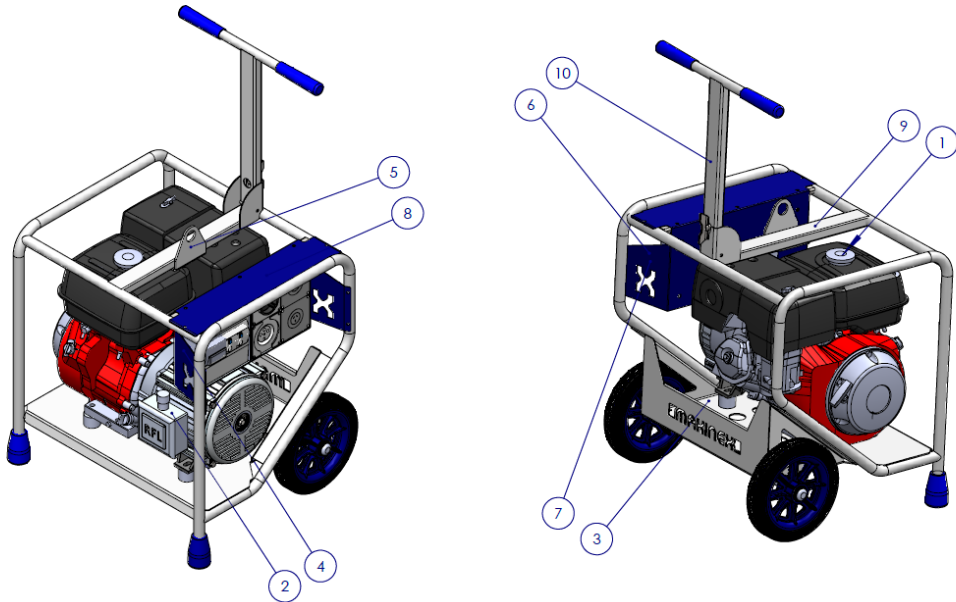

(1)



(3)



(5)

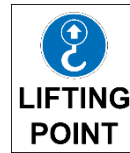

(7)



(2)



(4)



(6)



(8)

MAKINEX GEN-10P 10kVA <small>ENGINE: Honda OHV pull start FUEL TANK: 6.1L / 1.6 Gal</small>		<small>makinex.com</small>		
<p>⚠ DANGER</p> <p>CARBON MONOXIDE POISONOUS GAS See Manual</p> <ul style="list-style-type: none"> Use generator outdoors, away from open windows, vents, or doors. Generator exhaust contains carbon monoxide – a poisonous gas that can kill you. You CAN NOT smell or see this gas. Never use a generator in enclosed or partially-enclosed spaces. Install battery-operated carbon monoxide alarms or plug-in carbon monoxide alarms with battery back-up in your home. 	<p>USE OUTDOORS AVOID CARBON MONOXIDE POISONING</p>	<p>⚠ DANGER</p> <p>Failure to follow warnings, instructions and operators manual could result in death or serious injury</p> <p>GENERATOR COULD CAUSE ELECTRICAL SHOCK</p> <ul style="list-style-type: none"> Do not run indoors or wet weather Transfer switch must be used when connecting to a home's electrical system <p>HOT EXHAUST GASES COULD CAUSE FIRES. KEEP AT LEAST 5FT (1.5M) CLEARANCE FROM ANY COMBUSTIBLES OR STRUCTURES, INCLUDING OVERHEAD.</p> <ul style="list-style-type: none"> Point muffler away from home Do not touch hot parts Avoid hot exhaust gases 	<p>⚠ WARNING</p> <p>SHOCK</p> <p>A generator is a potential shock hazard which can result in serious injury or death.</p> <ul style="list-style-type: none"> Generator must be kept dry. Do NOT operate unit with wet hands. Generator MUST be grounded before use. See operators manual for specific instructions. Use extreme caution when refueling unit. RCBO receptacles must be tested before each use. See operators manual. Always keep generator four (4) feet from any structure. Always remove refueling gas can from generator area. This generator has an internal link between the neutral conductor and the earthed frame of the generator. 	<p>OPERATION Read Operator's Manual carefully before operating unit. Always make sure unit is level and properly grounded. Check engine oil before starting. See instructions located in operator's manual for starting procedure.</p> <p>START-UP</p> <ol style="list-style-type: none"> Turn on engine switch. Turn on fuel valve. Move choke lever to full choke. Pull the rope lightly until you feel some resistance, then apply a fast pull when the engine starts Slowly move choke lever to no choke. Allow unit to run two (2) minutes to warm-up with no load. Turn idle control switch to ON position. Loads can now be applied to unit. <p>SHUT-DOWN</p> <ol style="list-style-type: none"> Remove all load by turning off electrical appliances and unplugging electric cords. Allow engine to run at idle speed to cool two (2) minutes. Not allowing engine to cool may result in damage to unit. Turn the engine key to the OFF position. <p>TEST RCBO RECEPTACLE(S) BEFORE EACH USE. SEE OPERATORS MANUAL FOR INSTRUCTIONS.</p>

(9 & 10)



PRODUCT SPECIFICATIONS

GENERATOR:	GEN-10P		
MAX OUTPUT	10kVA		
FREQUENCY	50Hz		
VOLTAGE	240V		
MAX OUTPUT	8000W		
SOCKETS (WITH RCBO PROTECTION)	2 X 15A SINGLE PHASE + 1 X 20A 3-PHASE SOCKETS	2 X 15A SINGLE PHASE + 1 X 32A 3-PHASE SOCKETs	2 X 15A SINGLE PHASE SOCKETS
WEIGHT	102 kg		
NOISE LEVEL (7M)	NO LOAD - 72dB		
	50% LOAD - 76dB		
	100% LOAD - 78dB		
RATED POWER FACTOR	0.8		
ENGINE:			
TYPE	SINGLE CYLINDER AIR COOLED PETROL		
MODEL	HONDA GX390		
STARTING SYSTEM	PULL START		
DISPLACEMENT	389CC		
NET. POWER	7.8 kW @ 3000 RPM		
CONTINUOUS POWER	6.4 Kw @ 3000 RPM		
FUEL ECONOMY	2.4 L/h @ 50% LOAD		
FUEL TANK	6.5 L		



FEATURES

FEATURES
Durable Galvanised frame
Multi cushion isolators for vibration reduction
Compact design for easy storage and transport
Lifting point for transportation
RFL permanent magnet alternator

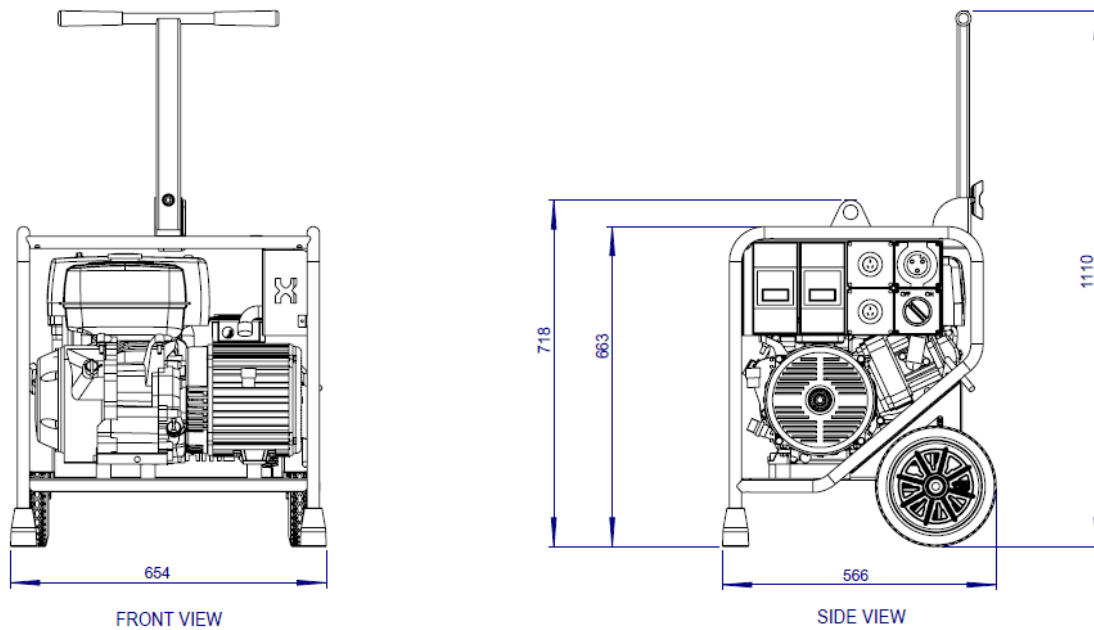
OVERALL MACHINE DIMENSIONS



ALTERNATOR SPECIFICATIONS

 RFL Alternators http://www.rflalternators.com			
Frame	132	Type	RF2 - 12.5
Enclosure	IP23	PM Brushless Alternator	
Poles	2	Phase	3
RPM	3000	Volts	415
Frequency	50 Hz	Amps	15.5
Power	10.0 kW	Motor Start kVA	14.0
Weight (kg)	40	Short Cir Amps	46.5
Ref Temp	27 °C	Serial No.	RF2-132-115-135-3P-1
 		EC. 1282. 0E140328. RFLQ093	

OPERATION

BEFORE USE

Before using the generator, ensure all the safety and operation instructions are read and the following steps are performed.

OIL LEVEL CHECK



CAUTION

Check the engine oil level with the engine stopped and in a levelled position

1. Clean area around oil fill and remove oil cap.
2. Check the dipstick to ensure there is enough oil.
3. If there is not enough oil, using oil funnel (optional), slowly pour contents into oil fill opening.
4. Replace oil fill cap and tighten.

NOTE: IMPROPER treatment of generator can damage it and shorten its life. DO NOT attempt to start the engine before it has been properly serviced with the recommended oil. This may result in an engine failure.

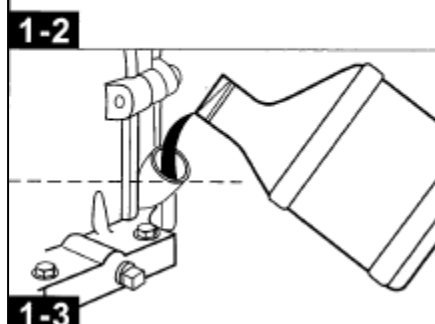
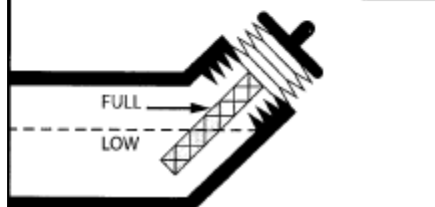
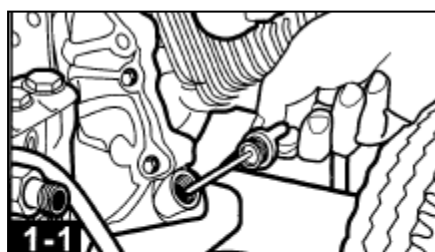

NOTE: Refer to GX390 Manual for more in-depth instructions

NOTE: New machines will be pre-oiled from MAKINEX with:
Honda Power Equipment Engine Oil – SAE 10W-30, API SJ

REFUELING



WARNING

FAILURE TO USE FUEL AS RECOMMENDED IN THIS MANUAL WILL VOID WARRANTY

- **DO NOT** use unapproved gasoline such as ethanol-based fuel.
- **DO NOT** mix oil with gasoline.
- **DO NOT** modify engine to run on alternate fuels.



WARNING

Fuel and fuel vapour are extremely flammable and explosive. Fire or explosion from misuse of fuel can cause severe burns and even death.



**FIRE
HAZARD**



WARNING

Always ensure that fuel tanks are filled outdoors.

- Turn generator **OFF** and let it cool for at least two minutes before removing fuel cap.
- Loosen fuel cap slowly to release pressure.
- Slowly add unleaded gasoline to fuel tank. **DO NOT** fill fuel above baffle to allow for appropriate space fuel expansion.
- Wait for spilled fuel to evaporate before starting the engine.



WARNING

Keep fuel away from sparks, open flames, pilot lights, heat and other ignition sources.



DO NOT light a cigarette or smoke near open fuel tank or container.

OPERATING GENERATOR



WARNING

Read and adhere to all safety and operation instructions.



Always have the brake down while it is stationary.

STARTING THE ENGINE

1. Remove all connections from the AC sockets.
2. Turn ON the fuel supply valve.
3. If you are starting the generator 'cold' set the choke lever to the ON position.
If the generator is warm skip this step.
4. Turn the ignition key to the START position.
5. Pull the starting handle lightly until you start to feel resistance and then pull up sharply to start the generator.
6. However if key start engine:
 - a) Ensure battery is connected and connection is secure.
 - b) Put the key in and turn clockwise to start the engine.
7. Once the engine has warmed up, set the choke lever to the OFF position.

CONNECTING ELECTRICAL DEVICES

The generator can supply 230V AC through 2 x 15amp sockets or 230V AC through 2 x 15amp sockets and 415V AC through the 20A socket.

1. Connect the appliance to the generator starting with the device that draws the most current.
2. Set the circuit breaker to 'ON'.

SHUTTING DOWN THE GENERATOR

1. Disconnect all appliances connected to the generator.
2. Turn the ignition key to the OFF position.
3. Set the fuel supply valve to OFF.

NOTE: To stop the generator in an emergency simply turn the ignition key to the off position.

MAINTENANCE

GENERAL RECOMMENDATIONS:

Regular maintenance will improve the performance and extend the life of the generator.

The generator's warranty does not cover items that have been subjected to operator abuse or negligence. To receive full value from the warranty, the operator must maintain the generator as instructed in this manual and in the engine user manual, including proper storage and regular servicing.



READ CAREFULLY

Regular maintenance is required to ensure performance of generator and to ensure warranty is not voided.

The maintenance schedule is in the engine owner's manual.

Should you have questions about replacing components on your generator, please contact dealer for assistance. MAKINEX dealers have access to all the special tools, technical information, parts and training required to maintain your MAKINEX product in peak operating condition.

Should you have questions about replacing components on your generator, please contact dealer for assistance.

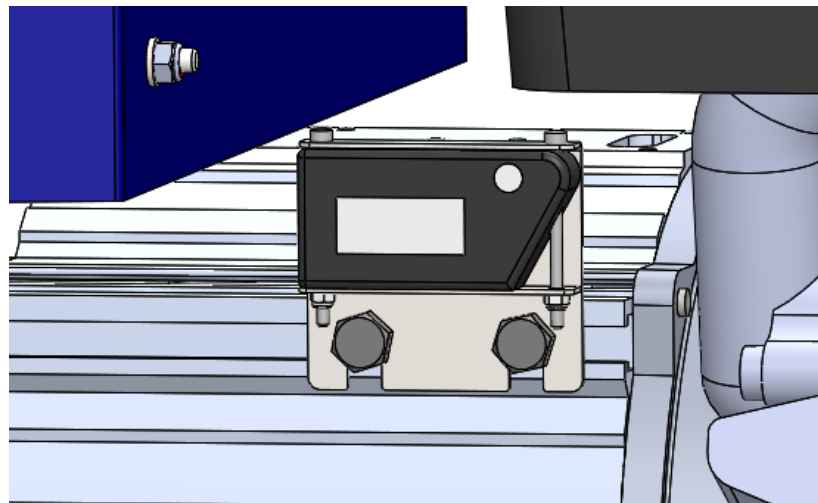

NOTE: An hour meter is installed on the machine to help with tracking operation hours.

STORAGE

STORAGE WITH FUEL IN TANK

Gasoline fuel can become stale when stored over **30 days**. Stale fuel causes acid and gum deposits to form in the fuel system or crucial carburettor parts. To keep fuel fresh:

1. Add a fuel stabiliser liquid additive to fuel.
2. Run engine for a minimum of 2 minutes to allow it to circulate throughout the engine



Fuel and fuel vapour are extremely flammable and explosive. Fire or explosion from misuse of fuel can cause severe burns and even death.



RUST PREVENTION IN CYLINDERS

1. Remove spark plugs and pour approx. 15ml (1/2oz) of clean engine oil into the cylinder.
2. Install spark plug and briefly turn the key starter for 1-2 seconds to distribute oil. **DO NOT** start engine at this time.
3. Slowly pull the recoil starter 2-3 times to distribute and coat the cylinder bore with oil.



Unintentional sparking can cause fire or electrical shock. Failure to observe this warning can cause severe property damage, severe burns and even death.

Disconnect spark plug wire from spark plug and cover tip of spark plug wire with insulating tape and place wire where it cannot come in contact with spark plug or generator frame.



Certain storage covers can be flammable or can melt in high temperatures. **DO NOT** place storage cover over generator until it has completely cooled.

LIMITED WARRANTY

In order to take advantage of the MAKINEX limited warranty, you must have maintenance performed according to the schedule (contained in relevant owner's manual supplied with this product, e.g. Engine operator's manual), by an authorised MAKINEX dealer or MAKINEX service technician. You are free to have your MAKINEX product serviced by any suitably qualified mechanic or electrician (depending on the mechanical or electrical requirement) and this will not affect your statutory warranties, however, failure by the owner to have the recommended servicing carried out by an authorised MAKINEX dealer/service technician means that you cannot take advantage of the MAKINEX limited warranty.

In order to ensure your safety, we strongly recommend that you only use an authorised MAKINEX dealer for servicing. Only authorised MAKINEX dealers have access to all the special tools, technical information, parts and training required to maintain your MAKINEX product in peak operating condition.

MAKINEX warrants each new Generator to be free from defects in material and workmanship under normal domestic and industrial use and service for the period specified below, conditional to the limitations and exclusions printed on this page. This warranty applies only to new MAKINEX generator distributed by us and by our authorised MAKINEX dealers.

Our goods come with guarantees that cannot be excluded under the Australian Consumer Law. You are entitled to a replacement or refund for a major failure and compensation for any other reasonably foreseeable loss or damage. You are also entitled to have the goods repaired or replaced if the goods fail to be of acceptable quality and the failure does not amount to a major failure.

WARRANTY: (Ex-factory/ Reseller premise)

MAKINEX warrants to the original purchaser:

- Frame and all Electrical components will be free of defects in material and workmanship for a period of one (1) year from the original date of purchase.
- Honda GX Engine is subject to (3) years warranty. Please see www.hondapowerequipment.com.au for details.
- Kohler KD Engine is subject to (3) years or 2000 hours warranty.
- Hatz B Series Engine is subject to (2) years or 2000 hours warranty.
- One(1) year warranty on RFL alternators

WARRANTY EXCLUSIONS

This warranty does not cover the following repairs and equipment:

NORMAL WEAR

Generator needs periodic parts and service to perform well. This warranty does not cover repair when normal use has exhausted the life of a part or the equipment as a whole.

INSTALLATION, USE AND MAINTENANCE

This warranty will not apply to parts and/or labour if this generator is deemed to have been misused, neglected, involved in an accident, abused, loaded beyond the generator's limits, modified and installed improperly. Normal maintenance such as spark plugs, air filters, adjustments, fuel system cleaning and obstruction due to build-up is not covered by this warranty.

OTHER EXCLUSIONS

This warranty excludes:

- Maintenance services cost.
- Freight costs.
- Cosmetic damage such as paint, decals, etc.
- Problems caused by accidents, improper storage, handling and shipping.
- Accessory parts such as starting batteries, fuses, spark plugs, and storage covers.
- Failures due to acts of God and other force majeure events beyond the manufacturer's control.
- Problems caused by parts that are not from the original manufacturer.

OWNER'S RESPONSIBILITY UNDER LIMITED WARRANTY:

Strict adherence to the maintenance checks and with **proof of scheduled maintenance history** is required by an authorised agent or qualified mechanic. It is the consumer's responsibility to deliver the machine in question to our service premises or to the premises of our appointed agent at the consumer's expense for replacement or repair as applicable. Maintenance services are not covered under warranty.

Claim Procedure:

- Contact MAKINEX by phone or email informing us of your machines problem or defect.
- Once the extent of the claim has been assessed, we retain the right to compensate the consumer for such defect, or repair (parts & labour), or replace the machine under warranty.
- All warranties will be carried out by MAKINEX authorised staff or appointed agents at a premises to be determined by the Manufacturer.

- Where the specific warranty component (e.g. Engine) is under a Manufacturer’s warranty other than MAKINEX (e.g. Honda, Hatz or Kohler etc.), the consumer can either contact MAKINEX or the applicable Manufacturer for repairs where such warranty was registered with that manufacturer at purchase.
- Warranty calls will only be carried out by our representatives and not via client’s choice of repairer. We will not accept back charges for any work not carried out by our representatives, or accept any charges due to equipment being un-operational for any reason even during its warranty period.

CONTACT INFORMATION

For sales, service, warranty and parts for all MAKINEX products; please refer below.

	SALES, SERVICE, SPARE PARTS & WARRANTY
--	---

<p>AUSTRALIA</p>	<p style="text-align: center;"><u>SALES</u></p> <p style="text-align: center;">TEL 1300 795 953 or +61 2 9460 8071 WEB www.makinex.com.au</p> <p style="text-align: center;"><u>SERVICE, SPARE PARTS & WARRANTY</u></p> <p style="text-align: center;">EMAIL service@makinex.com.au</p>
<p>USA</p>	<p style="text-align: center;"><u>SALES</u></p> <p style="text-align: center;">TEL +1 855-625-4639 WEB www.makinex.com</p> <p style="text-align: center;"><u>SERVICE, SPARE PARTS & WARRANTY</u></p> <p style="text-align: center;">EMAIL service@makinex.com</p>
<p>UK</p>	<p style="text-align: center;">WEB www.makinex.co.uk</p>
<p>EUROPE</p>	<p style="text-align: center;">TEL +31 (0)6 24881203 or +31 (0)6 50841849 EMAIL info@mttools.eu</p>
<p>CHINA</p>	<p style="text-align: center;">TEL +86 18951118278 EMAIL sales@makinex.com.cn</p>

Or your nearest MAKINEX distributor

We have very knowledgeable, experienced staff to assist you with help and advice.



APPENDICES

- **APPENDIX A- WIRING CIRCUIT DIAGRAM (2x15A)**
- **APPENDIX B- WIRING CIRCUIT DIAGRAM (2x15A + 1x20A 3P)**
- **APPENDIX C- RISK ASSESSMENT**

APPENDIX A- WIRING CIRCUIT DIAGRAM (2x15A)

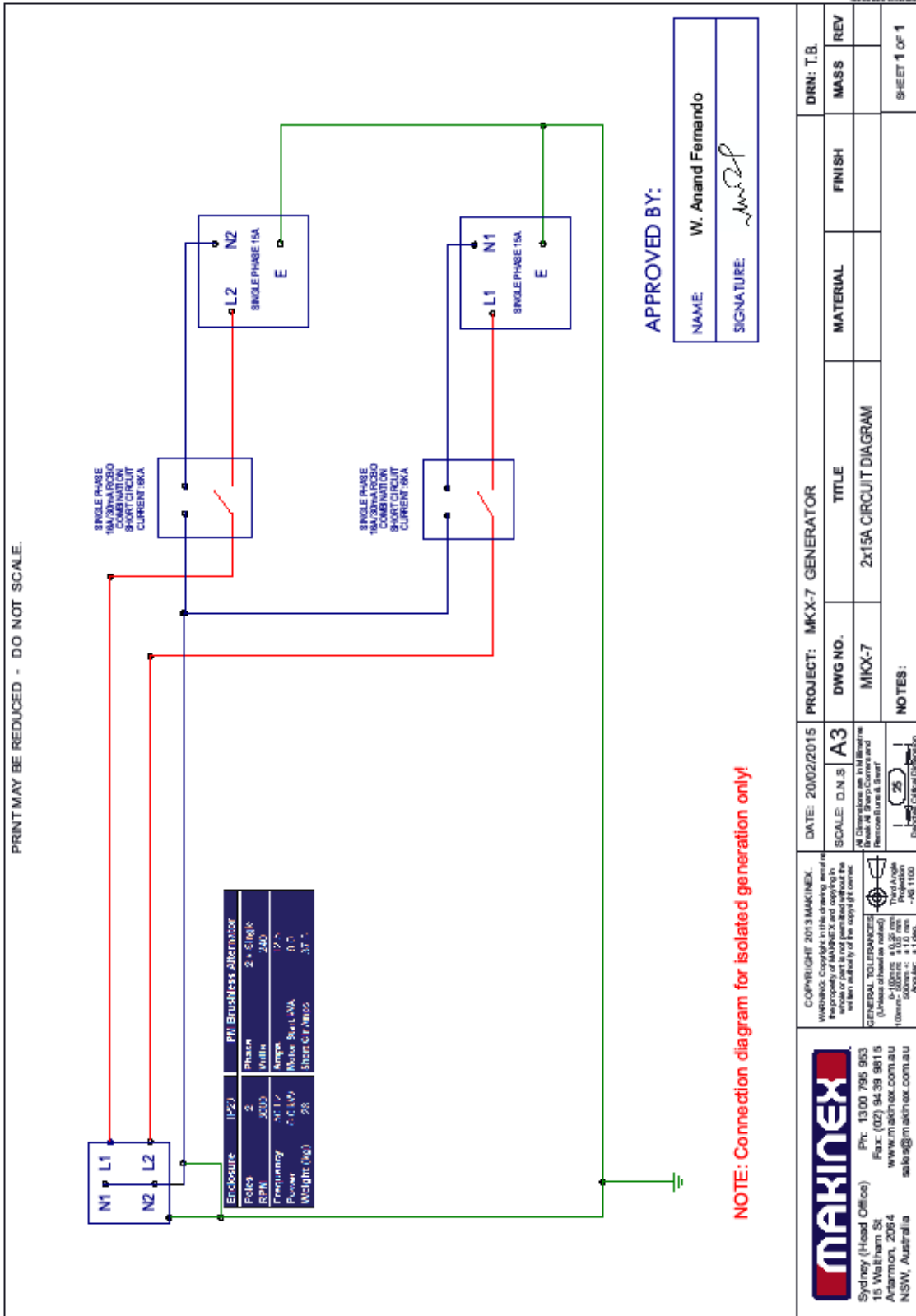

APPROVED BY:

NAME: W. Anand Fernando
SIGNATURE: *[Signature]*

<p style="font-size: 8px;">Sydney (Head Office) 15 Waltham St Artarmon, 2064 NSW, Australia Ph: 1300 795 953 Fax: (02) 9439 9815 www.makinex.com.au sales@makinex.com.au</p>	COPYRIGHT © 2013 MAKINEX. We warrant that the drawing and/or information contained herein is correct and complete and that we will defend the copyright owner.	DATE: 20/02/2015 SCALE: D.N.S A3	PROJECT: MKX-7 GENERATOR DWG NO.: MKX-7	DRN: T.B. MASS REV
	GENERAL TOLERANCES (Unless otherwise noted) 0-10mm: ±0.25mm 10-30mm: ±0.50mm 30-50mm: ±1.00mm Angular: ±1 deg.	25 Third Angle Projection -A6 1110	NOTES: 1. All dimensions are in millimeters unless otherwise stated. 2. Remove flange & gasket. 3. Remove flange & gasket.	TITLE: 2x15A CIRCUIT DIAGRAM MATERIAL: FINISH: SHEET 1 OF 1

APPENDIX B- WIRING CIRCUIT DIAGRAM (2x15A + 1x20A 3P)

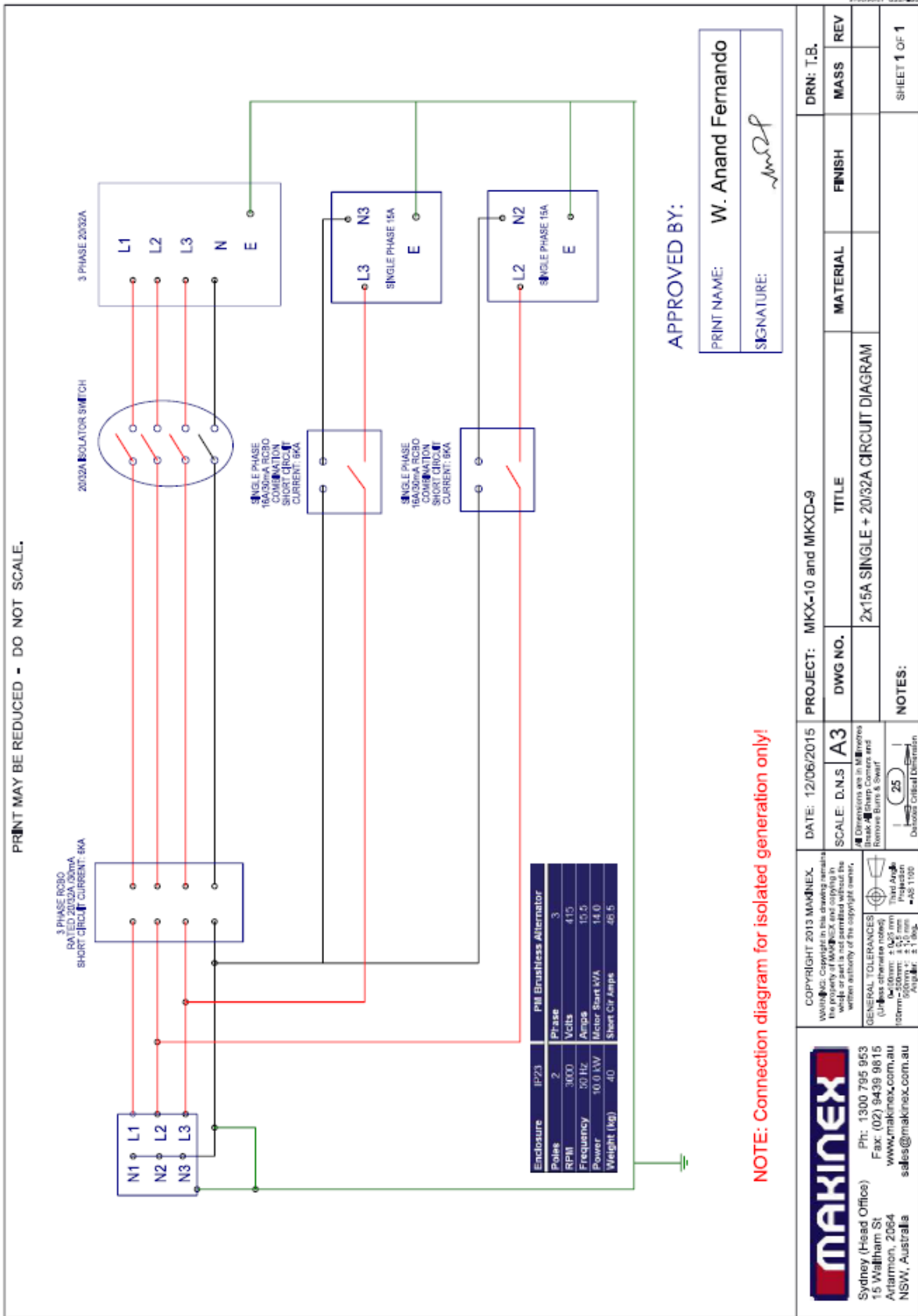

APPROVED BY:

PRINT NAME: **W. Anand Fernando**
 SIGNATURE: *[Signature]*

NOTE: Connection diagram for isolated generation only!

MAKINEX		Sydney (Head Office) 15 Wallham St Artarmon, 2064 NSW, Australia Ph: 1300 795 953 Fax: (02) 9439 9815 www.makinex.com.au sales@makinex.com.au	
COPYRIGHT 2013 MAKINEX. WARNING: Copyright in this drawing remains the property of MAKINEX and copying in whole or in part is not permitted without the written authority of the copyright owner.		DATE: 12/06/2015 SCALE: D.N.S Dimensions are in Millimetres Break: Sharp Corners and Remove Burrs & Swarf (Unless otherwise noted) (See drawing for Third Angle Projection) 10mm = 1/8" = 3.175 mm 50mm = 2" = 50.8 mm 100mm = 4" = 101.6 mm	
GENERAL TOLERANCES (Unless otherwise noted) 10mm: ± 0.25 mm 100mm: ± 0.50 mm 1000mm: ± 1.00 mm Finish: As per drawing		PROJECT: MKXX-10 and MKXD-9 DWG NO. A3 TITLE: 2x15A SINGLE + 20/32A CIRCUIT DIAGRAM NOTES:	
DRN: T.B. MASS REV		SHEET 1 OF 1	

APPENDIX C- RISK ASSESSMENT

PRODUCT RISK/ RISK HAZARDMENT ASSESSMENT	ASSESSMENT CARRIED OUT THOMAS BARNA
PRODUCT NAME: GEN-10P	DOCUMENT REVISION 001
MANUFACTURER: MAKINEX	DATE CREATED 03/04/2015
OPERATOR COMPETENCY: PLANT LICENCE NOT REQUIRED	

<p>NOTES:</p> <ul style="list-style-type: none"> > THIS PRODUCT HAS BEEN DESIGNED AND MANUFACTURED AS A HAND TRUCK WITH A POWERFUL LIFTING ARM ONLY > THIS DOCUMENT HAS BEEN PREPARED ACCORDING TO GUIDELINES AND RECOMMENDATIONS FOUND IN: <ul style="list-style-type: none"> 1. 'HAZPAK' PRODUCED BY THE WORK-COVER AUTHORITY AND 2. THE AUSTRALIAN STANDARDS 4024.1.4/5 - 1996 "SAFEGUARDING OF MACHINERY - PART 1: GENERAL PRINCIPLES AUSTRALIAN STANDARD, AS/NZS 3760 IN-SERVICE SAFETY INSPECTION AND TESTING OF ELECTRICAL EQUIPMENT. 	<p>"LIKELIHOOD LEVEL" REFERS TO THE PROBABILITY OF AN EVENT HAPPENING. THE FOLLOWING SCALE HAS BEEN USED TO DESCRIBE THE LIKELIHOOD OF A DEFINED RISK / HAZARD EVENT OCCURRING DURING NORMAL OPERATION OF THE EQUIPMENT. NOTE THAT LIKELIHOOD EVALUATION IS QUALITATIVE AND BASED ON BEST ESTIMATION VIA CONSULTATION AND EXPERIENCE:</p> <ol style="list-style-type: none"> 1. VERY LIKELY 2. LIKELY 3. UNLIKELY 4. VERY UNLIKELY 	<p>"CONSEQUENCE" REFERS TO THE SEVERITY OF INJURY CAUSED DUE TO AN EVENT OCCURRING. USING THE FOLLOWING SCALE AS DEFINED BY THE "HAZPAK" DOCUMENT:</p> <ol style="list-style-type: none"> 1. FATALITY = INJURIES RESULT IN DEATH 2. MAJOR = NORMALLY IRREVERSIBLE INJURIES 3. MINOR = REVERSIBLE INJURIES REQUIRING SEVERAL DAYS OFF 4. NEGLECTIBLE = ABLE TO BE TREATED USING FIRST AID 	<p>"RISK LEVEL" REFERS TO THE SEVERITY OF A RISK BASED ON THE "LIKELIHOOD LEVEL" AND "INJURY LEVEL" . INHERENTLY, AS THE CONSEQUENCE INCREASES IN SEVERITY, RISK INCREASES - EVEN WHEN LIKELIHOOD IS LOW - THE FOLLOWING SCALE HAS BEEN USED:</p> <ol style="list-style-type: none"> 1. HIGH = POTENTIAL DEATH, PERMANENT DISABILITY, OR MAJOR STRUCTURAL DAMAGE. 2. MEDIUM = POTENTIAL TEMPORARY, DISABILITY, OR MINOR STRUCTURAL DAMAGE. 3. LOW = POTENTIAL INCIDENT THAT HAS THE POTENTIAL TO CAUSE PERSONS TO REQUIRE FIRST AID. 						
<p>3.2</p>	<p>STRATING PORTABLE GENERATOR</p>	<p>3</p>	<p>UNLIKELY</p>	<p>3</p>	<p>MINOR</p>	<p>4</p>	<p>LOW</p>	<p>-</p>	<p>MANUAL HANDLING TECHNIQUE</p>
<p>4.1</p>	<p>NOISE</p>	<p>3</p>	<p>UNLIKELY</p>	<p>3</p>	<p>MINOR</p>	<p>3</p>	<p>MEDIUM</p>	<p>-</p>	<p>ALWAYS WEAR HEARING PROTECTION WHILST OPERATION AND/ OR IN CLOSE VICINITY OF THE MACHINE</p>

