



**MAKINEX**<sup>®</sup>  
RENEWABLES

## Hybrid Power System (HPS)

### HPSHV2030-AU



## OPERATOR'S MANUAL

Rev 01

# **Table of Contents**

<b>INTRODUCTION.....</b>	<b>3</b>
DISCLAIMER .....	3
ABOUT THIS MANUAL.....	4
<b>SAFETY INFORMATION.....</b>	<b>5</b>
GENERAL SAFETY INFORMATION .....	5
EARTHING.....	9
GENERAL SAFETY DECALS.....	10
<b>PRODUCT SPECIFICATIONS .....</b>	<b>12</b>
FEATURES .....	13
OVERALL MACHINE DIMENSIONS.....	14
<b>INSTRUCTION FOR USE.....</b>	<b>14</b>
BEFORE USE .....	15
WIRING HPS .....	20
OPERATING HPS.....	23
<b>DEYE CLOUD.....</b>	<b>33</b>
<b>MAINTENANCE.....</b>	<b>34</b>
GENERAL RECOMMENDATIONS.....	34
GENERAL TROUBLESHOOTING .....	35
STORAGE.....	36
TRANSPORT INFORMATION .....	36
<b>LIMITED WARRANTY .....</b>	<b>37</b>
WARRANTY EXCLUSIONS.....	38
OWNER'S RESPONSIBILITY UNDER LIMITED WARRANTY.....	39
<b>CONTACT INFORMATION .....</b>	<b>40</b>
<b>APPENDICES.....</b>	<b>41</b>
APPENDIX A – GENERATOR WIRING DIAGRAM .....	41
APPENDIX B – HPS SYSTEMS LINE DIAGRAM.....	44
APPENDIX C – RISK ASSESSMENT.....	45
APPENDIX D – WIND RATING CERTIFICATE .....	49
APPENDIX E – LIFTING CERTIFICATE.....	50

# INTRODUCTION

---

Thank you for purchasing a MAKINEX RENEWABLES product.

This manual provides information and procedures to safely operate and maintain the **HPS** Hybrid Power System. For your own safety and protection from injury, carefully read, understand, and observe the safety instructions described in this manual.

Keep this manual or a copy of it with the machine. If you lose this manual or need an additional copy, please contact MAKINEX RENEWABLES. This machine is designed and built with user safety in mind; however, it can present hazards if improperly operated and serviced. If there are any questions regarding operating or servicing of this machine, please contact MAKINEX RENEWABLES.

All rights, especially copying and distribution rights are reserved.

Copyright 2024 by MAKINEX RENEWABLES.

No part of this publication may be reproduced in any form or by any means, electronic or mechanical, including photocopying, without express written permission from MAKINEX RENEWABLES.

Any type of reproduction or distribution not authorised by MAKINEX RENEWABLES represents an infringement of valid copyrights and will be prosecuted. Makinex expressly reserves the right to make technical modifications, even without due notice, which aim at improving our machines or their safety standards.

## **DISCLAIMER**

---

MAKINEX RENEWABLES and its affiliates take no responsibility for any damage, injury or death resulting from the incorrect or unsafe use of this product. Use of this product should be undertaken by competent persons only. It is the operator's responsibility to ensure that the following safety procedures are followed. If you are unsure, do not operate this product.





Record the model and serial numbers as well as date and place of purchase for future reference. Have this information available when ordering parts and when making technical or warranty inquiries.

## ABOUT THIS MANUAL

---

This manual uses the following symbols to help differentiate between different kinds of information. The safety symbol is used with a key word to alert you to potential hazards in operating and owning power equipment. Follow all safety messages to avoid or reduce the risk of serious injury or death.

### KEY TERMS

 <b>READ CAREFULLY</b>	<b>READ CAREFULLY</b> – refers to <i>important information</i> that should be paid careful attention.
 <b>CAUTION</b>	<b>CAUTION</b> - indicates a potential hazardous situation which, if not avoided, <i>may</i> result in minor or moderate injury
 <b>WARNING</b>	<b>WARNING</b> – indicates a potentially hazardous situation which, if not avoided, <i>could</i> result in death or serious injury
 <b>DANGER</b>	<b>DANGER</b> – indicates an imminently hazardous situation which, if not avoided, <i>will</i> result in death or serious injury
 <b>PROHIBITED</b>	<b>PROHIBITED</b> – identifies actions that <i>should never</i> be carried out by anyone interacting with the machine.

These safety warnings do not eliminate all possible hazards that could occur therefore it is essential to use common sense and to strictly follow any instructions to prevent accidents.

# SAFETY INFORMATION

---

## GENERAL SAFETY INFORMATION

---

  
**WARNING** Read this manual **thoroughly** before operating your HPS. Failure to follow instructions could result in serious injury or death.

  
**WARNING** MAKINEX HPS Hybrid Power System is designed for professional operators only, instruct operators in care and use of the machine before use!

  
**WARNING** Keep children away from the product at all times.

  
**WARNING** Generator starts automatically.

- **ALWAYS** use in a well-ventilated area.
- **ALWAYS** have someone alert attending the machine when required.
- **ALWAYS** ensure the applied load does not exceed the product rating.
- **ALWAYS** disable the product when carrying out any maintenance.
- **ALWAYS** test the RCBO's before use.
- **ALWAYS** check the product for damage before use.
- **ALWAYS** keep well clear of all moving parts.
- **NEVER** allow children or animals near the product.
- **NEVER** use accessories or attachments not recommended by MAKINEX.
- **NEVER** alter or tamper with the internal wiring.
- **NEVER** climb or stand on the HPS.
- **NEVER** store or use the HPS in caustic environments.



### RISK OF HOT SURFACES

- Contact with hot surfaces, such as the engines exhaust components or electrical gear, could result in serious burns.

- **NEVER** touch any part of the engine, alternator, or exhaust when the generator is in use or immediately after use, as these get hot and could burn.



### RISK OF IMPALEMENT

- The wings on the HPS can move quickly in the upwards or downwards direction and can collide with and / or crush anything or anyone that is in the way.

- **NEVER** stand or leave anything in the path of the wing when opening or closing.



### RISK TO BREATHING

- Running engine gives off Carbon Monoxide, an odourless, colourless, poisonous gas.
- Breathing Carbon Monoxide can cause nausea, fainting or death.
- Some chemicals or detergents may be harmful if inhaled or ingested, causing severe nausea, fainting, or poisoning.



### EXHAUST FUMES CAN BE FATAL













- **ALWAYS** ensure that there is adequate ventilation when using the HPS.
- **ALWAYS** position the HPS so that the exhaust is pointing away from people or animals.
- **NEVER** use the HPS indoors or in an enclosed area.

## POSITIONING FOR SAFE USE



- **ALWAYS** leave at least a 2 metres (6 foot) gap between the generator and any surrounding building or structure.
- **ALWAYS** lift / drag the HPS from dedicated fork pockets / hook points on the base.
- **ALWAYS** ensure the HPS is on a solid, flat surface – use chocks / sleepers where necessary.
- **ALWAYS** ensure the surrounding area is free from any material that could burn or be damaged by heat.
- **NEVER** move or tilt the HPS whilst it is switched on.
- **NEVER** cover or enclose while in use.
- **NEVER** attempt to lift or move the HPS without suitable lifting equipment.



## ELECTRICITY-RELATED SAFETY PRECAUTIONS

 <b>WARNING</b>	<b>RISK OF ELECTRICAL SHOCK</b> <ul style="list-style-type: none"> <li>• Hazardous voltage, authorised access only</li> </ul>	 <b>ELECTRICAL HAZARD</b>
 <b>WARNING</b>	<b>MULTIPLE SUPPLIES</b> <ul style="list-style-type: none"> <li>• Isolate all supplies before working on the switchboard</li> </ul>	 <b>ELECTRICAL HAZARD</b>
 <b>WARNING</b>	<b>MULTIPLE DC SOURCES</b> <ul style="list-style-type: none"> <li>• Turn off / unplug all D.C sources to isolate equipment</li> <li>• Solar panels still produce a dangerous voltage even in open circuit state.</li> </ul>	 <b>ELECTRICAL HAZARD</b>
 <b>WARNING</b>	<b>MULTIPLE SUPPLIES</b> <ul style="list-style-type: none"> <li>• Isolate all supplies before working on the switchboard</li> </ul>	 <b>ELECTRICAL HAZARD</b>
 <b>WARNING</b>	<ul style="list-style-type: none"> <li>• This piece of equipment operates autonomously and produces hazardous AC &amp; DC voltages. Please ensure to follow all instructions thoroughly. All hardwired connections must be carried out by a licensed electrician. Risk of injury of death can occur.</li> </ul>	 <b>ELECTRICAL HAZARD</b>

- **ALWAYS** test the RCBOs before use.
- **ALWAYS** disengage the main battery breaker when performing any maintenance.
- **NEVER** try to repair electrical components if not authorised or qualified.
- **NEVER** use water or any other liquids to clean the unit while it is running.
- **NEVER** use any damaged electrical cord sets with the HPS.
- **NEVER** apply a load to, or use as a strap support, the solar panels on the HPS as they are fragile and will break if handled incorrectly.

## FIRE-RELATED SAFETY PRECAUTIONS

<b>EMERGENCY PROCEDURE</b>		
 <b>DANGER</b>	<ul style="list-style-type: none"><li>• In the event of fire in or around the battery system<ol style="list-style-type: none"><li>1. Call emergency services on <b>000</b>. Incident information - Fire involving lithium ion batteries.</li><li>2. <b>ONLY IF SAFE TO DO SO:</b> Follow shutdown procedure to turn off the solar / battery / inverter system.</li><li>3. <b>DO NOT</b> attempt to extinguish the fire yourself.</li><li>4. Evacuate the area and follow instructions of the emergency response personnel.</li></ol></li></ul>	 <b>FIRE HAZARD</b>

<b>RISK OF EXPLOSION OR FIRE</b>		
 <b>DANGER</b>	<ul style="list-style-type: none"><li>• Fuel and its vapours are extremely flammable and explosive</li><li>• Fire or explosion can cause severe burns or death</li></ul>	 <b>FIRE HAZARD</b>

- **ALWAYS** switch the engine **OFF** when refuelling.
- **ALWAYS** refuel away from any source of heat.
- **ALWAYS** refuel in a well-ventilated area.
- **ALWAYS** keep a fire extinguisher in the vicinity at all times.
- **NEVER** overfill fill the tank, fill to the level specified to allow for fuel expansion.
- **NEVER** smoke or use a naked flame while refuelling.
- **NEVER** start the engine if there is a fuel spill. Any spillage must be wiped clean and the generator allowed to dry before attempting to start the engine.
- **NEVER** leave any combustible materials on or close to the machine.



## **EARTHING**

---

Earthing of electrical systems helps protect the user from electric shock or electrocution which may be caused due to malfunction or breakdown. This threat to the user is prevented by creating a path of least resistance for the electrical current to travel to the ground which inherently absorbs the over-current or short circuit.

 <b>WARNING</b>	<b>DO NOT TOUCH ANY COMPONENTS IF YOU ARE NOT A QUALIFIED ELECTRICIAN.</b>	 <b>ELECTRICAL HAZARD</b>
---	--	---

 <b>WARNING</b>	<b>FAILURE TO PROPERLY CONNECT THE EQUIPMENT TO THE EARTHING CONDUCTOR WILL RESULT IN A RISK OF ELECTROCUTION. CONSULT WITH A QUALIFIED ELECTRICIAN IN CASE OF DOUBT WITH THE EARTHING OF THE UNIT.</b>
---	---

 <b>READ CAREFULLY</b>	<b>ANY OTHER GROUNDING INSTALLATION MUST BE CARRIED OUT BY A LICENSED ELECTRICIAN AND ALL LOCAL CODES MUST BE FOLLOWED.</b>
--	---

We strongly recommend that all applicable federal, state, and local regulations relating to grounding/earthing specifications be checked and followed.

# GENERAL SAFETY DECALS

## I/O Panel Front Door

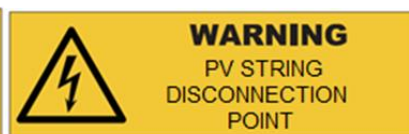
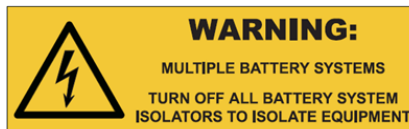
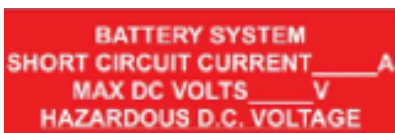

## Solar Panel Transport locks



**WARNING**  
NO WELDING  
OR DRILLING

SAFE FILL  
400 LITRES

**DANGER**  
NO SMOKING  
NO NAKED FLAME



# PRODUCT SPECIFICATIONS

---

<b>MODEL:</b>	<b>HPSHV-2030-AU</b>
<b>GENERATOR:</b>	Pacelink PLG-YM22S-N
<b>INVERTER:</b>	Deye 29.9K-SG01HP3-AU
<b>BATTERY:</b>	6x Deye BOS-G Pro Lithium Batteries
<b>SOLAR:</b>	8 x TRINA 500W PANELS (4.0 kW total)
<b>MAX CONTINUOUS OUTPUT</b>	20 kW
<b>SURGE OUTPUT (10 s)</b>	40kW
<b>RATED FREQUENCY</b>	50 Hz
<b>RATED POWER FACTOR</b>	0.8
<b>OUTLET SOCKETS</b>	1 x 15A 230VAC (RCBO Protected) 1 x 63A 400VAC HARD WIRE
<b>DRY WEIGHT</b>	2584Kg
<b>DIMENSIONS (PACKED DOWN)</b>	2366 x 1530 x 2544 mm LENGTH x WIDTH x HEIGHT
<b>DIMENSIONS (DEPLOYED)</b>	4376 x 5129x 2216 mm LENGTH x WIDTH x HEIGHT
<b>NOISE LEVEL (GENERATOR)</b>	66 dB @ 7 m
<b>TELECOMMUNICATION</b>	4G & WIFI GPS

## **FEATURES**

---

<b>FEATURES</b>
Generator backup for excess power needs and extended poor weather affecting solar generation
Customisable programs for generator run time/quiet time
Telecommunications for full remote programming, cloud monitoring and alarms
GPS tracking and cellular coverage
Quick & easy deployment
Folding design for easy storage and transport
Durable Galvanised frame
Fork pockets and tie downs for transportation
Wind rating: 38 m/sec (136 km/h)*
Air-conditioned electrical cabinet

\* It is recommended that at a wind speed of 30 m/s (108 km/h) the wings are folded down.

# OVERALL MACHINE DIMENSIONS

Deployed:

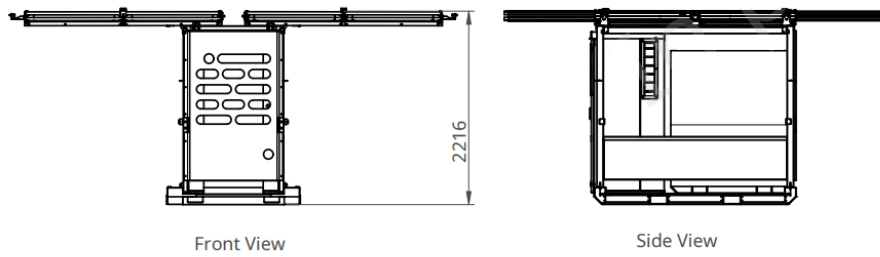
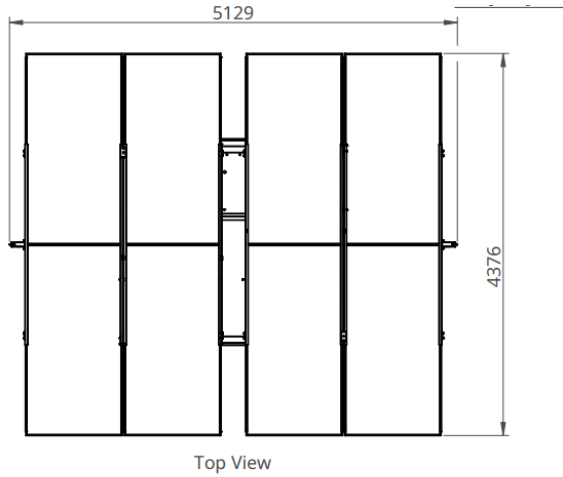

Folded Down:

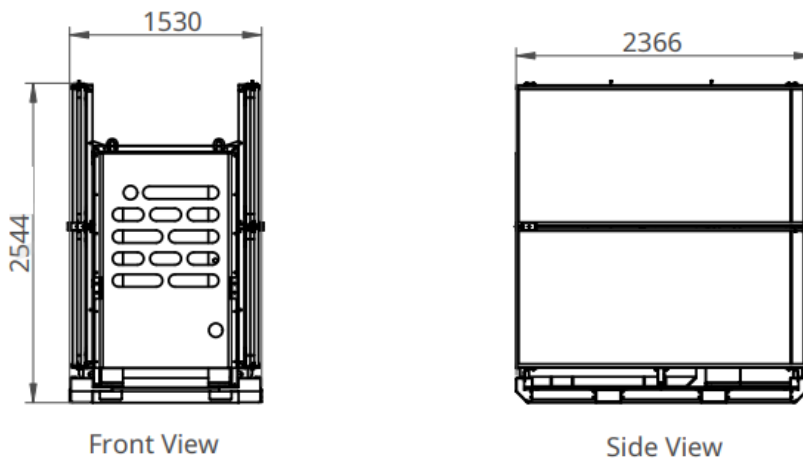



**NOT TO SCALE**  
 Dimensions in mm

## INSTRUCTION FOR US



Read and adhere to all safety and operation instructions.

 <b>READ CAREFULLY</b>	<p>Battery supply located in electrical cabinet</p> <p><b>HPSHV-2030-AU:</b>  Short circuit current: 3.96 kA (DC)  Max DC Volts: 350 VDC</p>
 <b>READ CAREFULLY</b>	<p>PV Array Located on roof of frame  PV Array Open Circuit Voltage: 206.8 V DC / PV String, 2 Strings total  PV Array Short Circuit Current: 12.28 A DC / PV String, 2 Strings total</p>
 <b>READ CAREFULLY</b>	<p>This HPS contains Earth Neutral Link and RCD protection via Inverter for operator safety.</p>

## ***BEFORE USE***

---

Before using the product, ensure all the safety and operation instructions are read, and the following steps are performed.

Note: Familiarise yourself with the location of Emergency Stops, connections and orientation of the HPS.

## **PRE-DEPLOYMENT CHECKS**

General frame checks:

- Earth stake present (connection for earth stake located inside the hardwire connection box)
- Check all panels secure and locking pins correctly in place
- Check outriggers are working, and locking bolts are present

Generator:

- Check for leaks
- Fluid level checks (engine oil, coolant, fuel)

Electrical:

- Test 16A RCBO

## **DEPLOYMENT**

Ensure HPS is positioned away from any hazards and on a level, even surface.

It may be necessary to place the system on chocks to create a level pad or to elevate the unit in case of localised flooding.

Ensure there is at least 2 metres clearance from 'collapsed' skid to allow solar wings to open.

Ensure the HPS will not be subjected to shade from trees or surrounding structures when solar wings are open to maximise solar power generation.

1. Remove the 'Transport Locks' at each end (4 in total). They will store by hanging from the attached shackles.

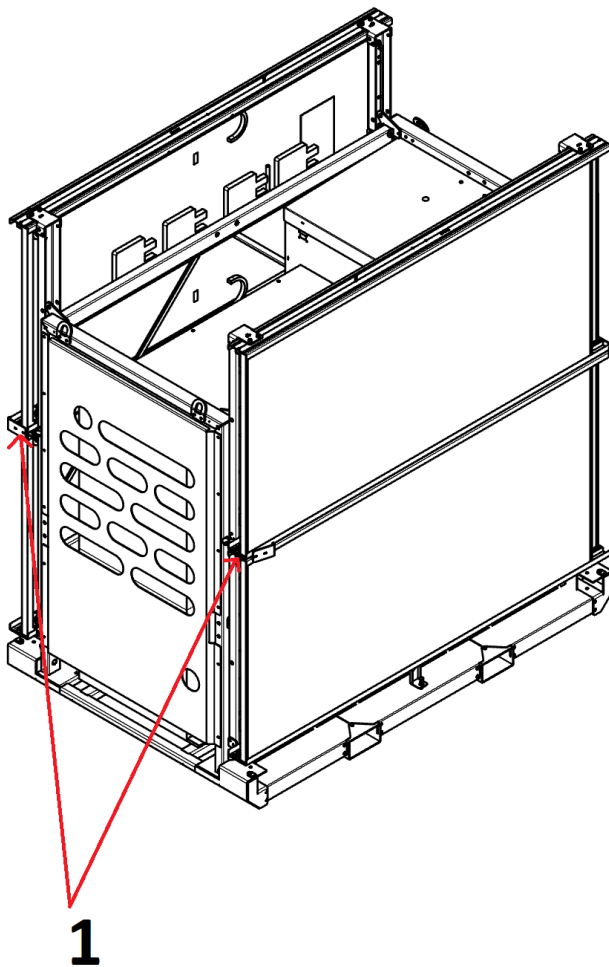

2. Slide each of the solar panels out until they stop.



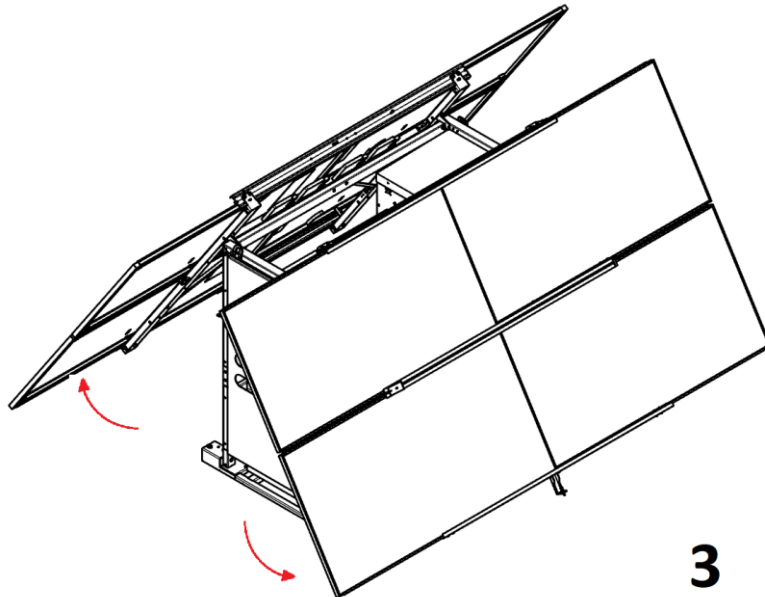
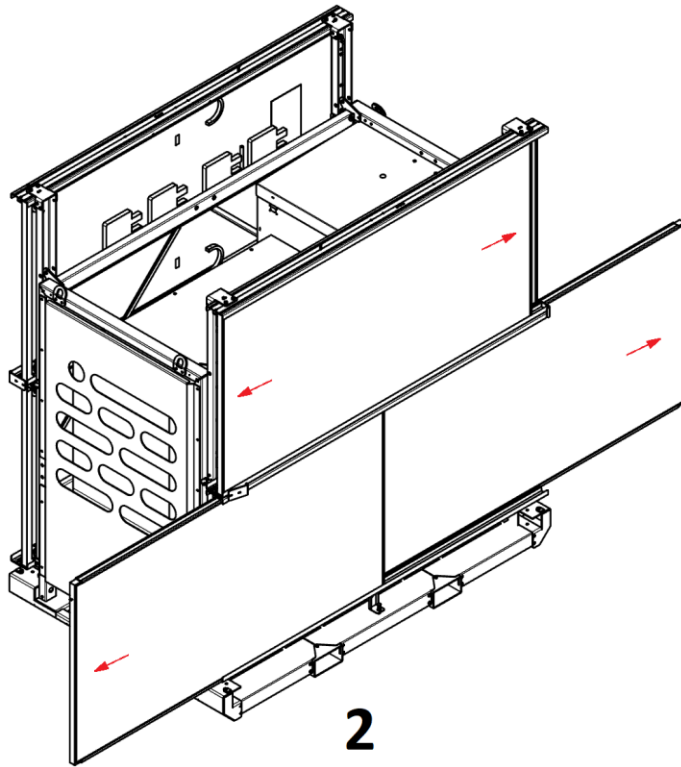

3. Standing at the centre of the wing, pull from the bottom outwards to allow the gas struts to deploy and assist with raising the wing. A slight push upwards will be required to raise the wing to full height. Make sure you hear an audible click as the locking pins on the yellow stays engage. Check these pins visually also to confirm they are seated correctly.

Note: The next step (4) requires deploying the outriggers. Make sure to check the locking tab which secures the outrigger in the deployed position. It will need to be rotated 90 degrees when opening and closing the outriggers.

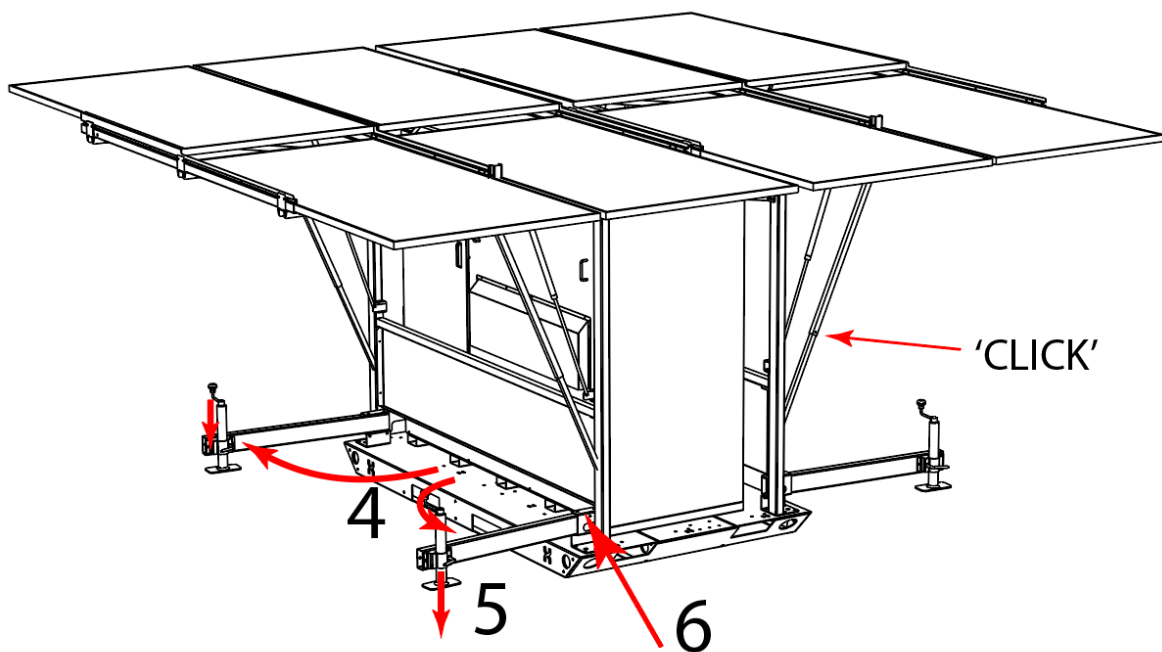
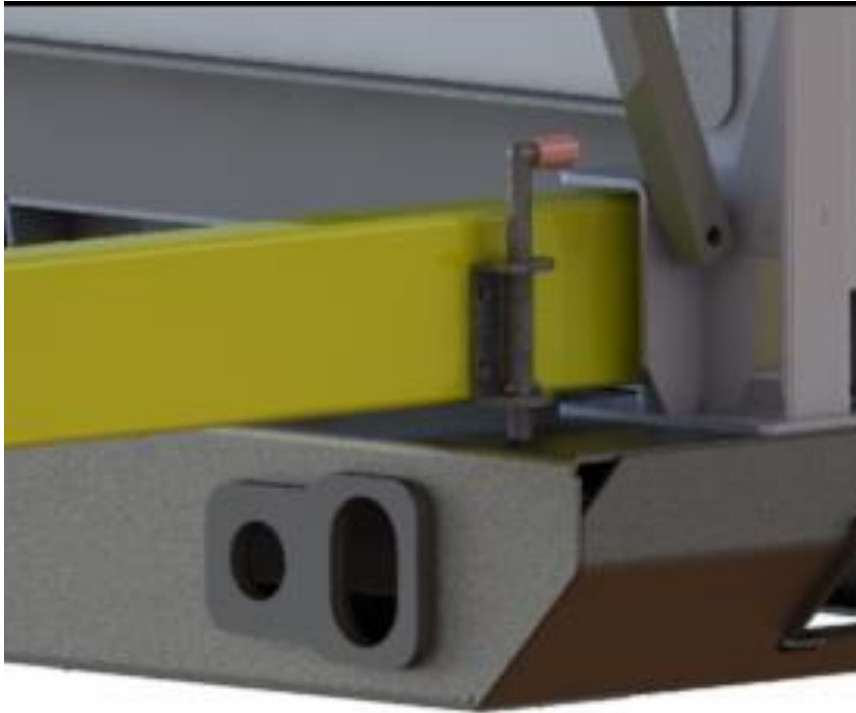

4. Open the outriggers
5. Wind down the adjustable stand. It is recommended that a timber block (sleeper) is placed under each outrigger to form a stable, solid surface.
6. Ensure the outrigger locking tab is in place as per previous note.
7. Install earth stake as per local electrical regulations



8. Connect the HPS using either the outlets or the hardwired terminals. If using the hardwired terminals, this must be done by a suitably qualified electrician.

**Note1:**

The inverter has RCD and Earth Fault Detection protecting all output supply. Connections to Hardwired terminals should be conducted by a licensed electrician.

**Note 2:**

The HPS is fitted with a MEN at the hardwire outlet which can be removed as required by site wiring.

**Important:** The site must have only one MEN, preferably in the HPS to ensure safety. A registered electrical contractor must ensure earthing system is as per relevant electrical safety standards.

# WIRING HPS

## MEN LINK IN HPS

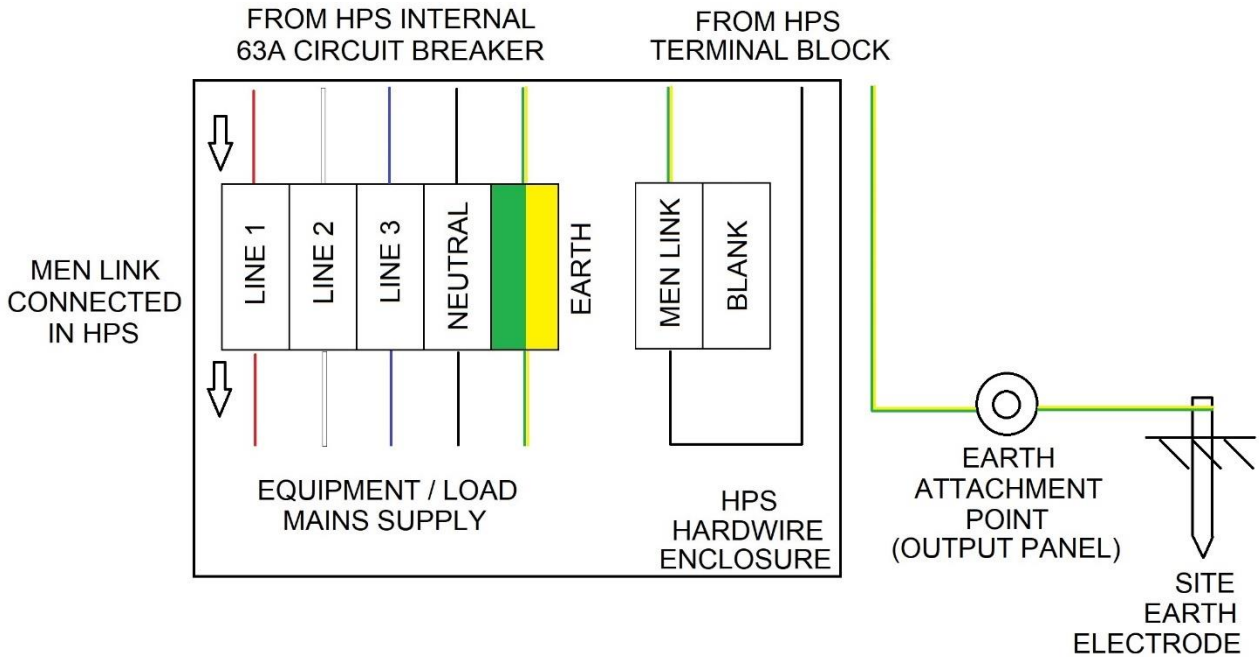

## MEN LINK OUTSIDE HPS

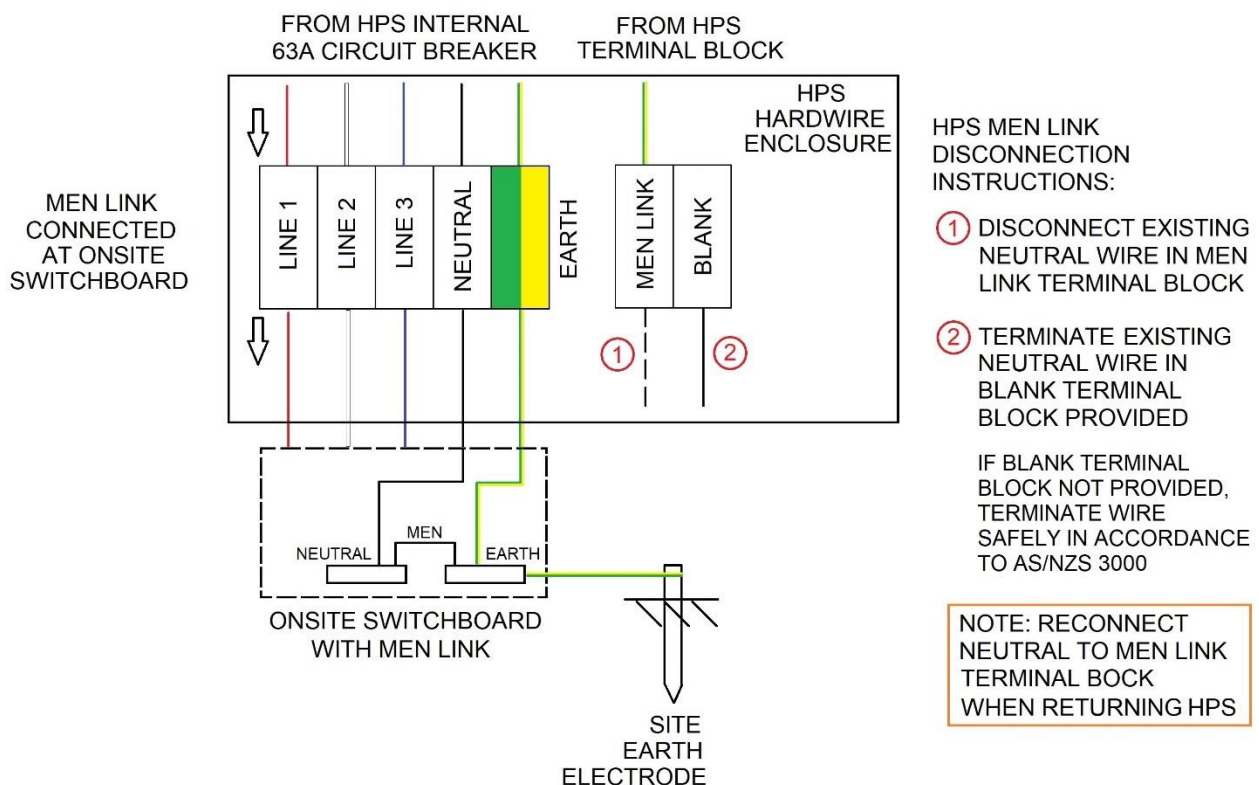

## GENERATOR

The generator control panel 'Power Switch' is to remain ON when the HPS system is deployed and active.



If the HPS system is not deployed or in storage, turn OFF the 'Power Switch'.



Refer to generator supplier documents and manual for generator troubleshooting and service manuals.

## REFUELING



**FAILURE TO USE FUEL AS RECOMMENDED IN THIS MANUAL WILL VOID WARRANTY**

- Use **DIESEL** fuel only
- **DO NOT** modify engine to run on alternate fuels.



**Fuel and fuel vapour are extremely flammable and explosive. Fire or explosion from misuse of fuel can cause severe burns and even death.**



**FIRE HAZARD**



**Always ensure that fuel tanks are filled outdoors.**

1. Ensure the generator is not running.
2. Loosen fuel cap slowly to release pressure.
3. Slowly add diesel to tank. **DO NOT** over fill.
4. Clean up any spilled fuel before starting the engine.



**Keep fuel away from sparks, open flames, pilot lights, heat and other ignition sources.**

**DO NOT** light a cigarette or smoke near open fuel tank or container.



## OPERATING HPS



Read and adhere to all safety and operation instructions.

### PRE-START CHECKLIST

- 1) Check that the Emergency Stop at the outlet and generator panel is released



- 2) On the outlet panel, turn ON:
  - a. AC MAIN Circuit Breaker
  - b. GENERATOR INLET Circuit Breaker
  - c. UTILITY 15A Circuit Breaker
  - d. AC PV INLET Circuit Breaker



- 3) On the Generator Panel, turn ON:
  - a. Power Switch
  - b. Ensure Generator Battery Isolator is ON
  - c. Generator will boot up in Auto Mode



## HPS STARTUP & OPERATION PROCEDURE

- 1) Turn ON the Main Switch at the Outlet Panel. Follow the On-Screen Instructions to Initialise and Startup System.



- 2) STARTUP CONTROL Screen – Ensure all is Green. Then - Press to Continue.

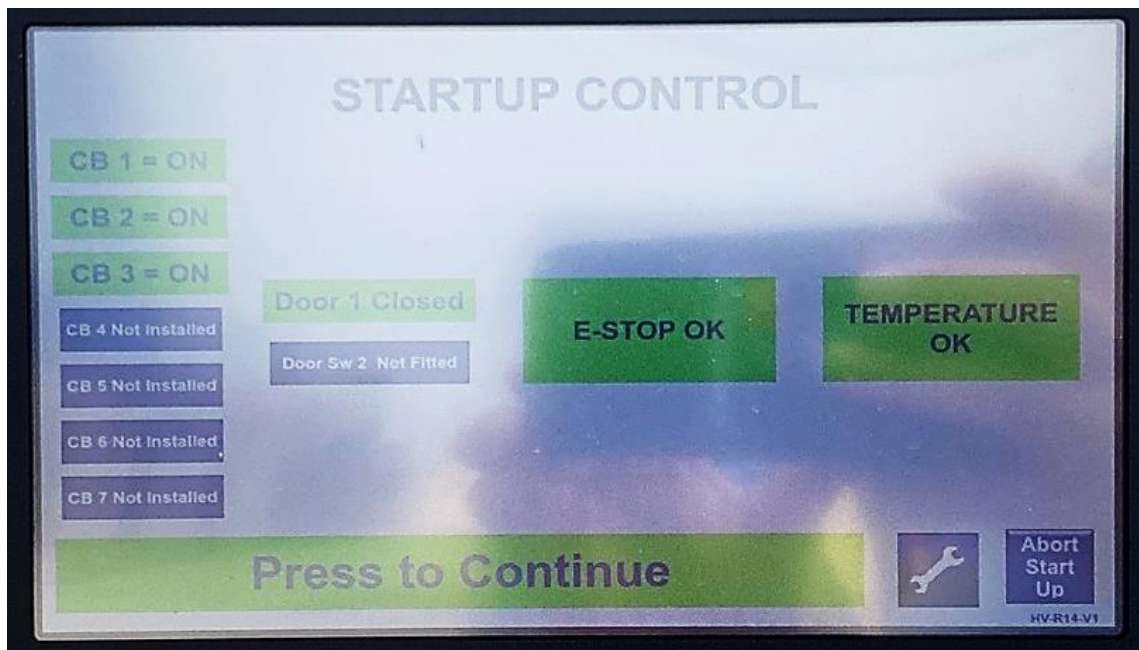



- 3) SYSTEM READY Screen
  - a. Press on screen START button.  
Or
  - b. Turn the Main Switch to the Right position.

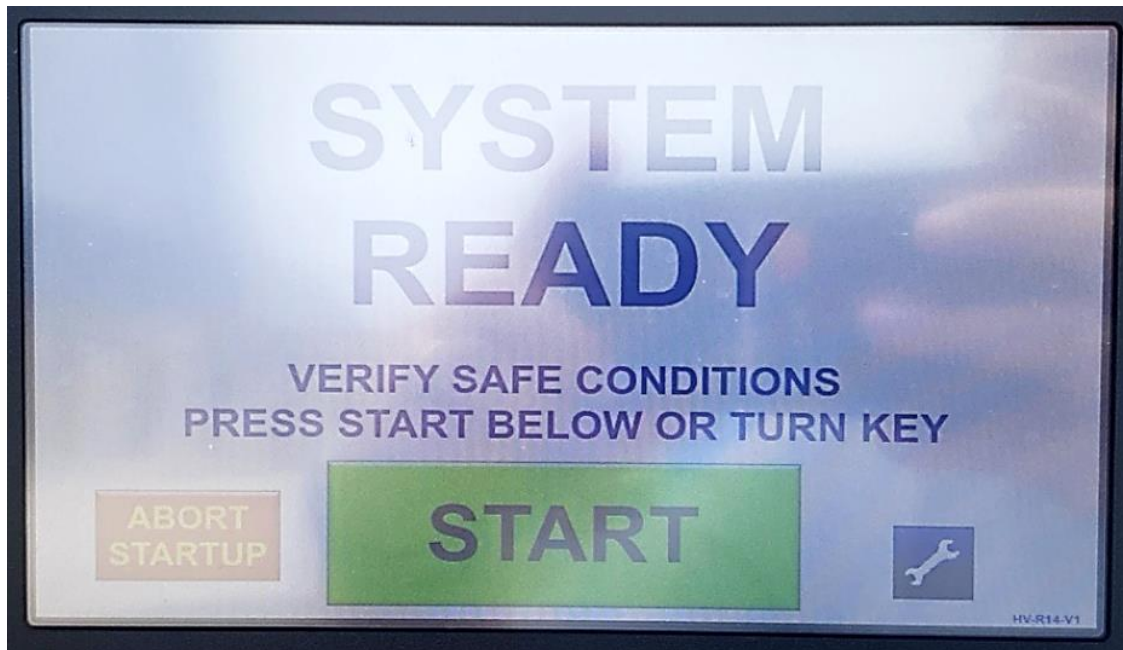

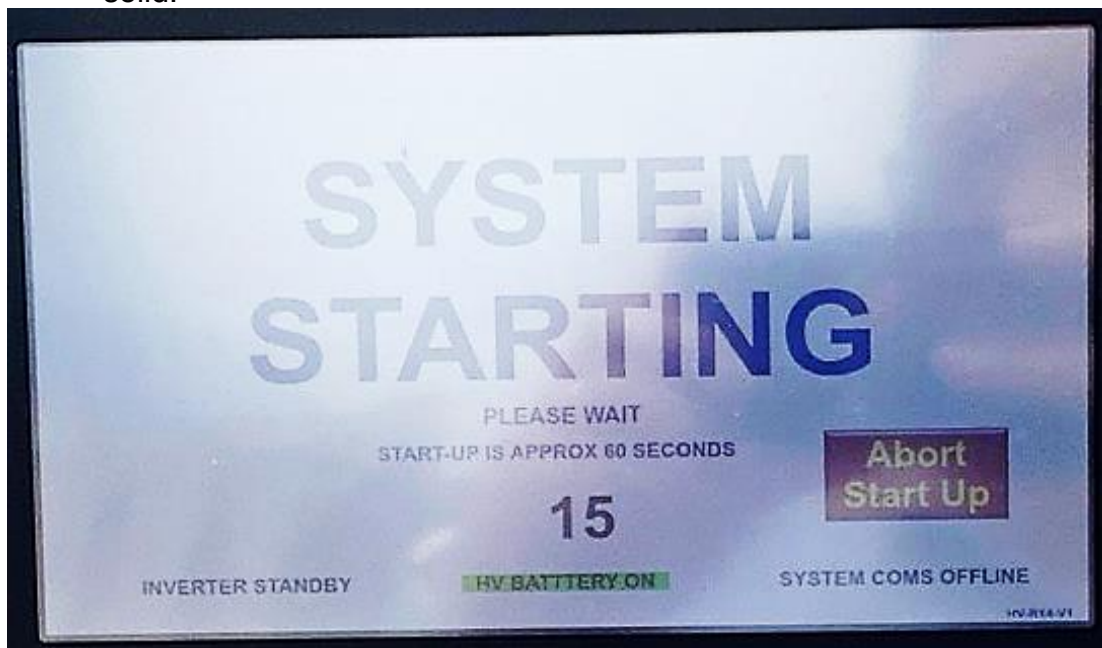

- 4) SYSTEM STARTING Screen
  - a. Wait for the Dashboard to appear. The Green LED will be flashing while booting up.
  - b. Once the Dashboard appears, AC Output is ready. The Green LED will be solid.

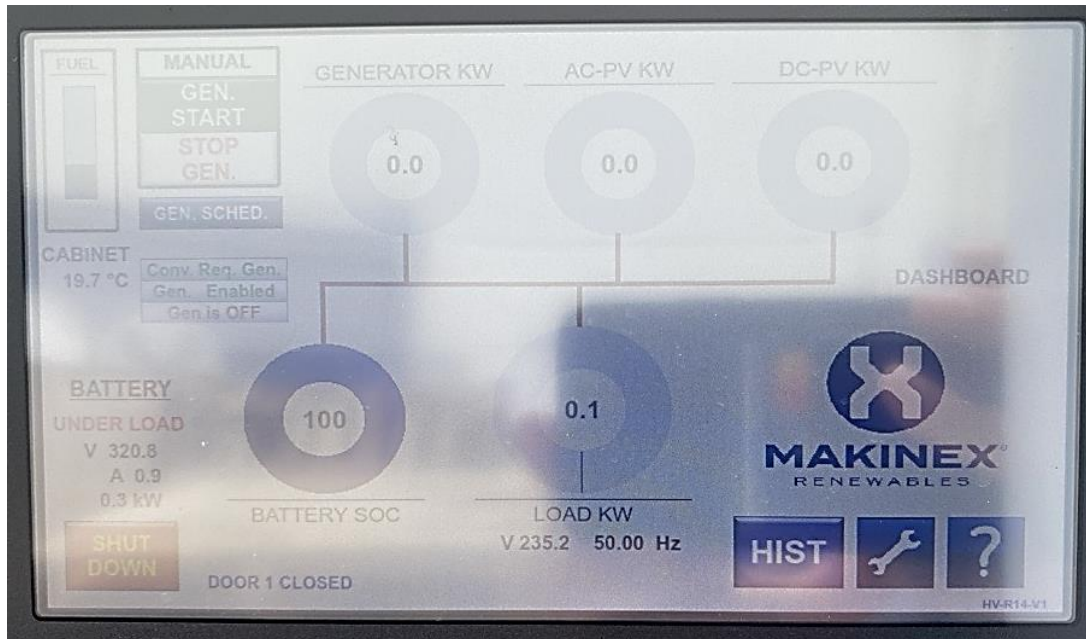

## 5) DASHBOARD Screen



### GENERATOR START/STOP SOC SET POINT

- 1) Press the  on the Dashboard Screen.
- 2) Adjust the Start and Stop SOC Setting as shown below.
- 3) Press the  to return back to the Dashboard Screen.

The defaults are:

- START: 30%
- STOP: 95%
- HEAT: 0C
- COOL: 25C



## GENERATOR SLEEP SCHEDULE

The Generator Sleep Schedule is used to prevent the Generator starting at specific time in Auto Mode when called for.

Two schedules can be set. Time is set in 24Hr format. Increments of 0.10 (10 mins).

**Note:** Manual Start of the generator bypasses this schedule and allows the Generator to start.

- 1) Press "GEN SCHED." on the Dashboard Screen.

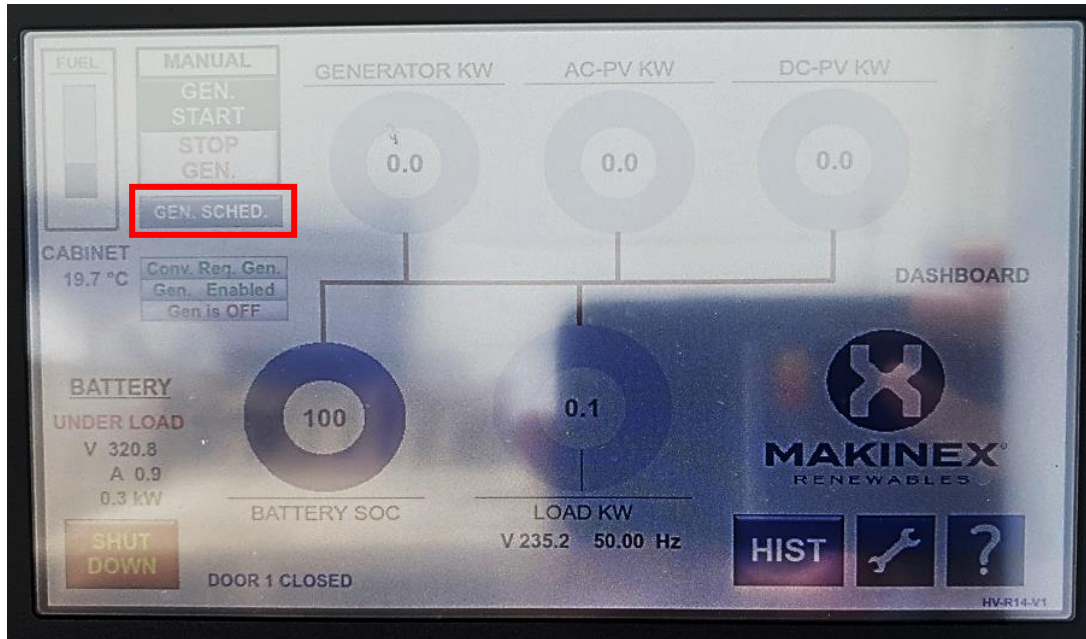

- 2) Set schedule as required.

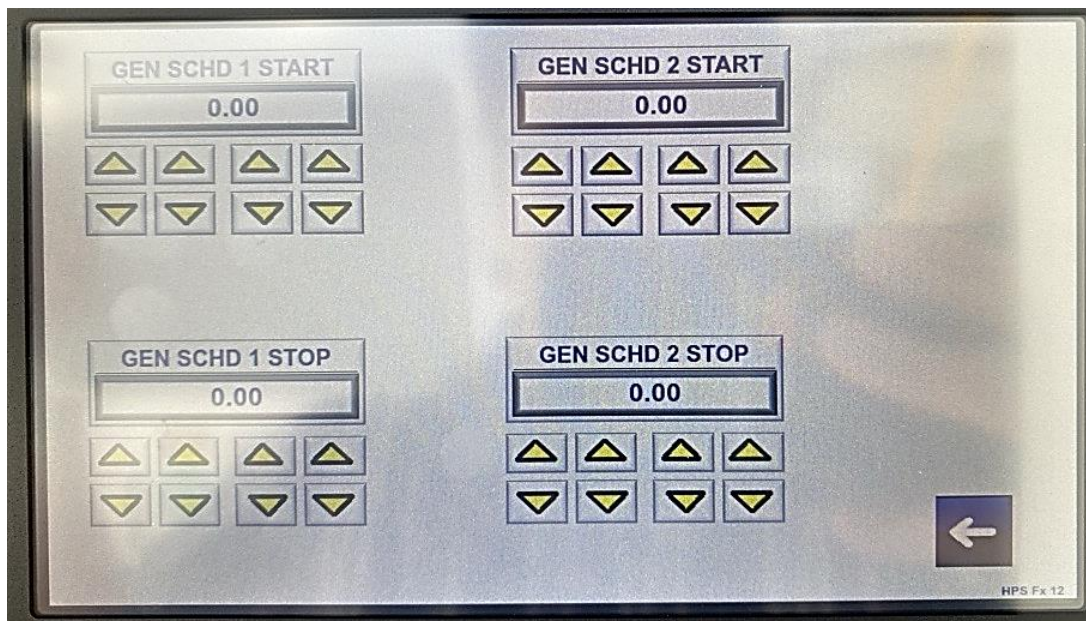

### For Example:

- The generator will not start between the time 12:00am and 6:00am.
  - Gen Schd 1 Start: 24.00
  - Gen Schd 1 Stop: 6.00
- The generator will not start between the time 6:00pm and 8:00pm.
  - Gen Schd 2 Start: 18.00
  - Gen Schd 2 Stop: 20.00

## GENERATOR MANUAL START IN AUTO MODE

Starting the Generator manually in Auto Mode will allow for manual charging of batteries and load stacking output.

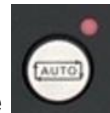

- 1) Ensure the Generator is still in Auto Mode



- 2) Press "GEN START" and wait for the Generator to start.
- 3) Press "GEN STOP" to stop the Generator.

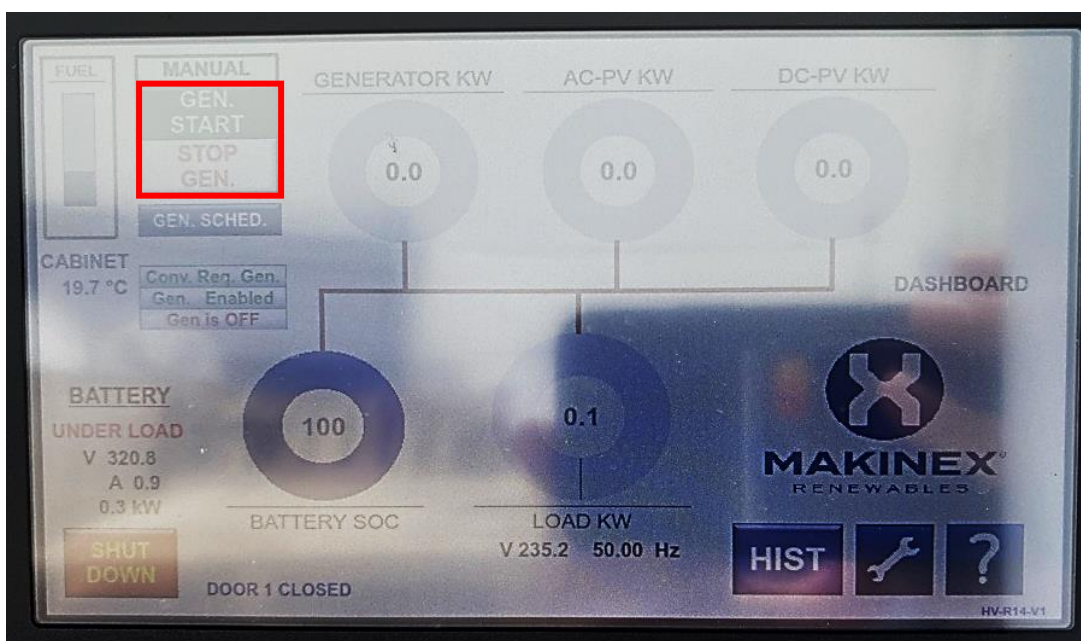

## **HPS LOAD OUTPUT STACKING PROCEDURE**

Load output stacking is a feature that can combine the generator power and battery capacity to provide a greater output than the nominal power output rating of the system for a short period of time.

For the maximum advantage of the feature, ensure the SOC of the system is above 90%.

- 1) While the HPS is outputting normally. Start the Generator manually as indicated above.
- 2) Ensure initial load is below 16kW (Generator Input Power limited via Inverter).
  - a. This is to prevent overloading the Generator when it starts.
- 3) Wait for the Generator to start and begin charging the batteries.
- 4) While the Inverter is in Battery charging mode, load can now be increased to the Load Stacking Output Rating.
- 5) Load Output in Stacking mode can be operated between 30% - 90%.
- 6) It is recommended to decrease the load below the rating of the system and stop Load Stacking once the SOC is near 30%.

This is to prevent the system shutting down from 0% SOC shutdown and overloading the Generator.

- 7) Remember to turn OFF the Generator on the Dashboard when Load Stacking is not required.

The Generator should start automatically again if the SOC is below the Set 30% to charge the batteries.

**Note:** During Load Output Stacking mode, the SOC of the batteries will decrease significantly in a short period of time. Time will vary depending on the load.

## **HPS INVERTER BYPASS/TRANSFER PROCEDURE**

The Bypass/Transfer function is to only use the Generator to supply to the load in case of inverter or battery fault.

- 1) Turn OFF the HPS via the Hard Shut Down Procedure.
  - a. Turn OFF the Main Switch
- 2) Ensure the following Circuit Breakers on the I/O panel is turned OFF.
  - a. AC MAIN
  - b. GENERATOR INLET
  - c. AC PV IN
- 3) The RCBO, SCADA and AIR CON Circuit Breakers is to remain turned ON.
- 4) Open the Electrical Enclosure Door.
- 5) Locate the Bypass Circuit Breaker behind. The SCADA and AIR CON Circuit Breakers is to remain turned ON.

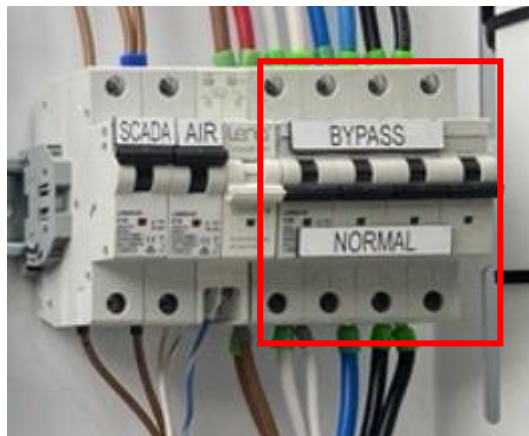

- 6) Switch to the BYPASS Position (Circuit Breaker ON).
- 7) Close the Electrical Enclosure Door and lock accordingly to ensure the Door Interlock is closed properly.
- 8) Turn the Generator ON and start in Manual Mode.

- 9) Press  for Manual Mode.

- 10) Press ON Button  to start the Generator.

- 11) Wait for Generator to be ready for output, loads can be turned ON. Loads can be up to the Generator's rated power output.

- 12) Reverse the above steps to stop Bypass/Transfer mode and revert to NORMAL operation.

## HPS SHUT DOWN PROCEDURE

There are two methods to shut down the HPS System.

### **Method 1:** Soft Shut Down.

This will shut down the system and stops outputting AC supply.

The HMI will return to the START UP CONTROL Screen and ready to be initialised again.

### **Method 2:** Hard Shut Down.

This will shut down the system and stops outputting AC supply.

The HMI will turn OFF, all controls systems, inverters and batteries will deenergise and turn OFF, all breakers will be automatically opened. The whole system will be cold.

**Note:** The Hard Shut Down method is to be used for servicing or packing for storage.

### **Soft Shut Down:**

- 1) Press 'Shut Down' button on the Dashboard Screen.
- 2) Press 'Yes' when prompted to Shut Down system.

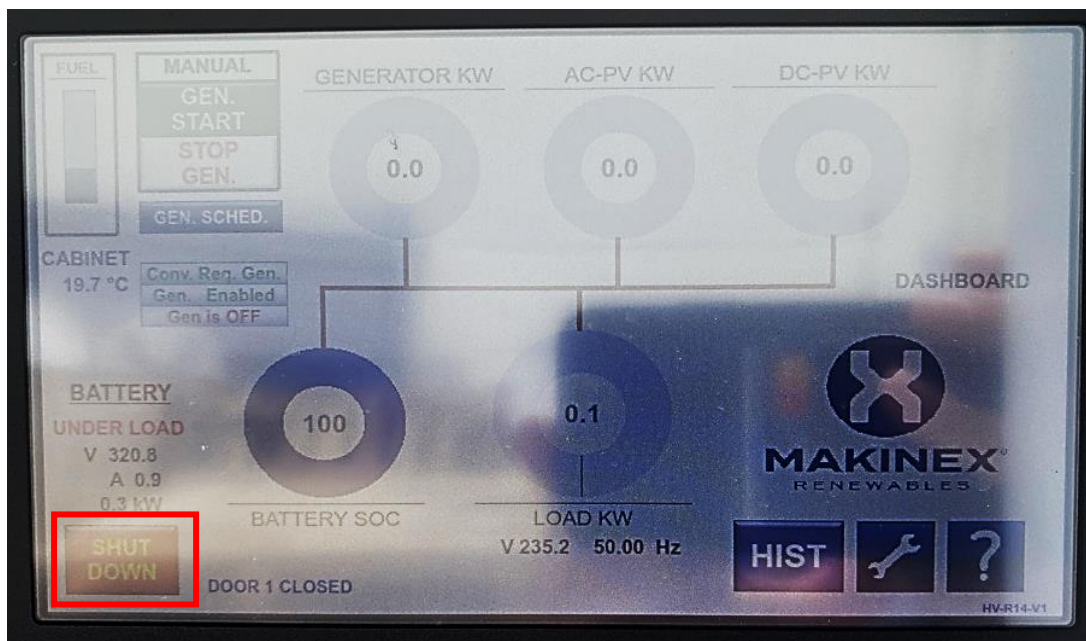

## Hard Shut Down:

- 1) Turn OFF the Main Switch on the outlet panel.

The AC MAIN, GENERATOR INLET and AC PV IN Circuit Breakers will shunt OFF when Hard Shut Down is initiated.



**NOTE:** To stop the HPS in an emergency, simply press either of the **EMERGENCY STOP** buttons



## PACKING DOWN

1. Shut down the HPS using the Hard Shut Down indicated above.
2. Turn OFF Generator Power Switch.
3. Pack the HPS down in the reverse order of the deployment, making sure all four transport locks are in place and secure.



## DEYE CLOUD

---

As the owner of the HPS system you will be granted viewer access to the unit on the Deye Cloud. Your MAKINEX RENEWABLES representative will assist you with this process.

When you are setup and logged in, you will see other users with access to your system. These are there for your ongoing support needs.

Set up your Deye Cloud account as 'Registered Owner' at:  
<https://www.deyecloud.com/reg/0>

Share your account email with your Makinex representative so that they can add your installation to your Deye Cloud account.

Make yourself familiar with the Deye Cloud portal.

The Deye Cloud App can also be downloaded to Mobile devices.

Download APP



# MAINTENANCE

---

## **GENERAL RECOMMENDATIONS**

---

Regular maintenance will improve the performance and extend the life of the HPS.

The HPS warranty does not cover items that have been subjected to operator abuse or negligence. To receive full value from the warranty, the operator must maintain the HPS as instructed in this manual and in the **Generator** user manual, including proper storage and regular servicing.



**READ  
CAREFULLY**

**Regular maintenance is required to ensure performance of HPS and to ensure warranty is not voided.**

**The generator maintenance schedule is in the generator owner's manual.**

Should you have questions about replacing components on your HPS, please contact dealer for assistance. MAKINEX RENEWABLES dealers have access to all the special tools, technical information, parts and training required to maintain your MAKINEX RENEWABLES product in peak operating condition.

## **GENERAL HPS CHECKS**

It is considered good practice to check the HPS before and after use, looking at:

- Condition of electrical components (especially Circuit Breakers for loose connections over time);
- Earthing bolts are tight;
- Condition of engine mounts;
- Fuel line conditions;
- Oil and fuel levels;
- Any possible leaks;
- Any significant structural damage.
- Check wiring to solar panels is not crimped or damaged

## GENERAL TROUBLESHOOTING

PROBLEM	POSSIBLE CAUSES	CORRECTIONS
<b>ENGINE WILL NOT START</b>	Out of fuel.	Add fresh fuel.
	Low engine oil.	Fill up with oil.
	Low battery.	Charge the battery.
	Engine requires servicing.	Contact authorised Makinex dealer
<b>ENGINE LACKS POWER</b>	Stale fuel.	Drain the fuel tank and then add fresh fuel.
	Dirty air filter.	Replace or clean air filter.
	Fault in alternator.	Contact authorised Makinex dealer
	Engine requires servicing.	Contact authorised Makinex dealer
<b>HPS IS ON BUT NO AC OUTPUT</b>	Circuit breaker tripped	Unplug all appliances from sockets and reset the circuit breaker.
	Faulty appliance.	Connect with another appliance that is in good condition.
	Fault in generator	Contact authorised Makinex dealer
<b>NO BATTERY PERCENTAGE SHOWING</b>	HPS has been switched on from complete shutdown	Allow HPS to complete an entire charge cycle
<b>UNIDENTIFIED</b>	Contact authorised Makinex dealer for assistance.	

For other engine problems or further instructions, refer to the provided generator user manual.

## ***STORAGE***

---

### **BATTERY STORAGE PRECAUTIONS**



**READ  
CAREFULLY**

**Batteries deplete over time.** Ensure to follow the below steps.

After use of the HPS, follow these precautions to ensure the batteries do not drain whilst in storage or not in use.

1. Fully charge the HPS before putting into long term storage. The batteries will deplete over time, so it is essential they are stored with sufficient charge.
2. Ensure the system is completely OFF, the Main Switch is OFF, Generator power switch is OFF.

### ***TRANSPORT INFORMATION***

---

It is important to be familiar with the rules and regulations in your state or territory regarding transporting dangerous goods (D.G.).

The HPS contains lithium-ion batteries, classified as a dangerous good by the criteria of the ADG code. UN 3480

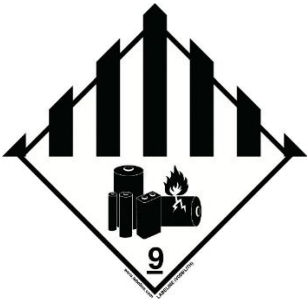

UN number	3480
Proper shipping name	Lithium-ion batteries (limited to a maximum of 30% SoC)
Class or division	9
Label(s) / Placard Required	Miscellaneous Lithium batt

Talk to your Makinex representative for assistance and refer to the supplied Deye Battery Safety Data Sheet (SDS)

## LIMITED WARRANTY

To take advantage of the MAKINEX RENEWABLES limited warranty, you must have maintenance performed according to the maintenance schedule (contained in **generator** owner's manual supplied with this product), by an authorised MAKINEX RENEWABLES dealer or MAKINEX RENEWABLES service technician. You are free to have your MAKINEX RENEWABLES product serviced by any suitably qualified mechanic or electrician (depending on the mechanical or electrical requirement) and this will not affect your statutory warranties, however, failure by the owner to have the recommended servicing carried out by an authorised MAKINEX RENEWABLES dealer/service technician means that you cannot take advantage of the MAKINEX RENEWABLES limited warranty.

MAKINEX RENEWABLES warrants each new HPS to be free from defects in material and workmanship under normal domestic and industrial use and service for the period specified below, conditional to the limitations and exclusions printed on this page. This warranty applies only to new MAKINEX RENEWABLES products distributed by us and by our authorised MAKINEX RENEWABLES dealers.

Under the limited warranty and at MAKINEX RENEWABLES's discretion, upon evaluation, inspection and testing by a MAKINEX RENEWABLES dealer or a MAKINEX RENEWABLES service technician, MAKINEX RENEWABLES will repair and replace of defective part(s).

AUSTRALIA: Our goods come with guarantees that cannot be excluded under the ACL. You are entitled to a replacement or refund for a major failure and compensation for any other reasonably foreseeable loss or damage. You are also entitled to have the goods repaired or replaced if goods fail to be of acceptable quality and the failure does not amount to a major failure.

### **WARRANTY: (Ex-factory/ Reseller premise)**

MAKINEX RENEWABLES warrants to the original purchaser:

- Frame and all Electrical components will be free of defects in material and workmanship for a period of 2 years from the original date of purchase.
- Generator - 1 years / 1000 hours;
- Batteries - 2 years limited warranty;
- Inverter – 2 years;
- Solar panels – 2-years limited product warranty

## **WARRANTY EXCLUSIONS**

---

This warranty does not cover the following repairs and equipment:

### **NORMAL WEAR**

Generator needs periodic service and genuine parts to perform well. This warranty does not cover repair when normal use has exhausted the life of a consumable part for example the oil filter and fuel filter.

### **INSTALLATION, USE, AND MAINTENANCE**

This warranty will not apply to parts and/or labour if this HPS is deemed to have been misused, neglected, involved in an accident, abused, loaded beyond the HPS's limits, modified and installed improperly. Normal maintenance such as spark plugs, air filters, adjustments, fuel system cleaning and obstruction due to build-up is not covered by this warranty.

### **OTHER EXCLUSIONS**

This warranty excludes:

- Excessive battery cycling due to improperly sized system for the application loads
- Operation, storage or transport of the unit not in accordance with the instructions outlined in this manual
- Maintenance services cost.
- Expedited freight costs.
- Cosmetic damage such as paint, decals, etc.
- Problems caused by accidents, improper storage, handling and shipping.
- Accessory parts such as starting batteries, fuses, spark plugs, and storage covers.
- Failures due to acts of God and other force majeure events beyond the manufacturer's control.
- Problems caused by parts that are not from the original manufacturer.

## ***OWNER'S RESPONSIBILITY UNDER LIMITED WARRANTY***

---

Strict adherence to the maintenance checks and with **proof of scheduled maintenance history** is required by an authorised agent or qualified mechanic. It is the consumer's responsibility to deliver the machine in question to our service premises or to the premises of our appointed agent at the consumer's expense for replacement or repair as applicable. Maintenance services are not covered under warranty.

### **Claim Procedure:**

- Contact MAKINEX RENEWABLES by phone or email informing us of your machines problem or defect.
- Once the extent of the claim has been assessed, we retain the right to compensate the consumer for such defect, or repair (parts & labour), or replace the machine under warranty.
- All warranties will be carried out by MAKINEX RENEWABLES authorised staff or appointed agents at a premise to be determined by the Manufacturer.
- It is the responsibility (and cost) of MAKINEX RENEWABLES or our appointed agent to return the machine to be repaired or replaced under warranty to the consumer- this is valid for domestic territories only (e.g. Australian units will be delivered within Australian territories and European units will be delivered within its designated country's territories).
- Where the specific warranty component (e.g. Inverter) is under a Manufacturer's warranty other than MAKINEX RENEWABLES (e.g. Deye, Pacelink or Trina etc.), the consumer can either contact MAKINEX RENEWABLES or the applicable manufacturer for repairs where such warranty was registered with that manufacturer at purchase.
- Warranty calls will only be carried out by our representatives and not via client's choice of repairer. We will not accept back charges for any work not carried out by our representatives or accept any charges due to equipment being un-operational for any reason even during its warranty period.

## CONTACT INFORMATION

---

For sales, service, warranty and parts for all MAKINEX RENEWABLES products; please refer below.

	<b>SALES, SERVICE, SPARE PARTS &amp; WARRANTY</b>
<b>AUSTRALIA</b>	<p style="text-align: center;"><b><u>SALES</u></b></p> <p style="text-align: center;">TEL 1300 795 953 or +61 2 9460 8071 WEB <a href="http://www.makinex.com.au">www.makinex.com.au</a></p> <p style="text-align: center;"><b><u>SERVICE, SPARE PARTS &amp; WARRANTY</u></b></p> <p style="text-align: center;">EMAIL <a href="mailto:support@makinex.com.au">support@makinex.com.au</a></p>

**Or your nearest MAKINEX distributor**

We have very knowledgeable, experienced staff to assist you with help and advice.





# APPENDICES

## APPENDIX A – GENERATOR WIRING DIAGRAM

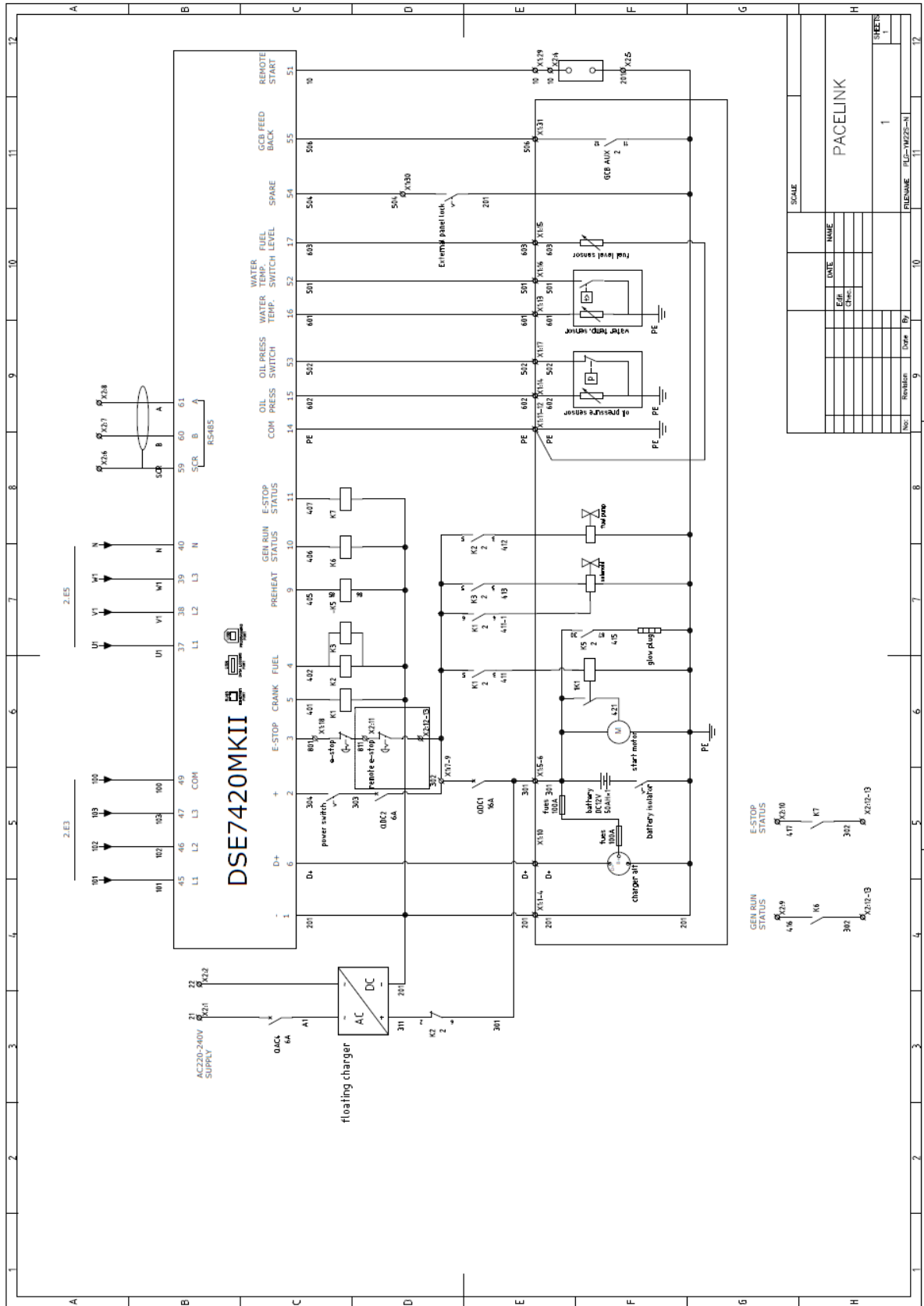



## Emergency Stop Wiring to Generator Modifications for V1.0 SCADA

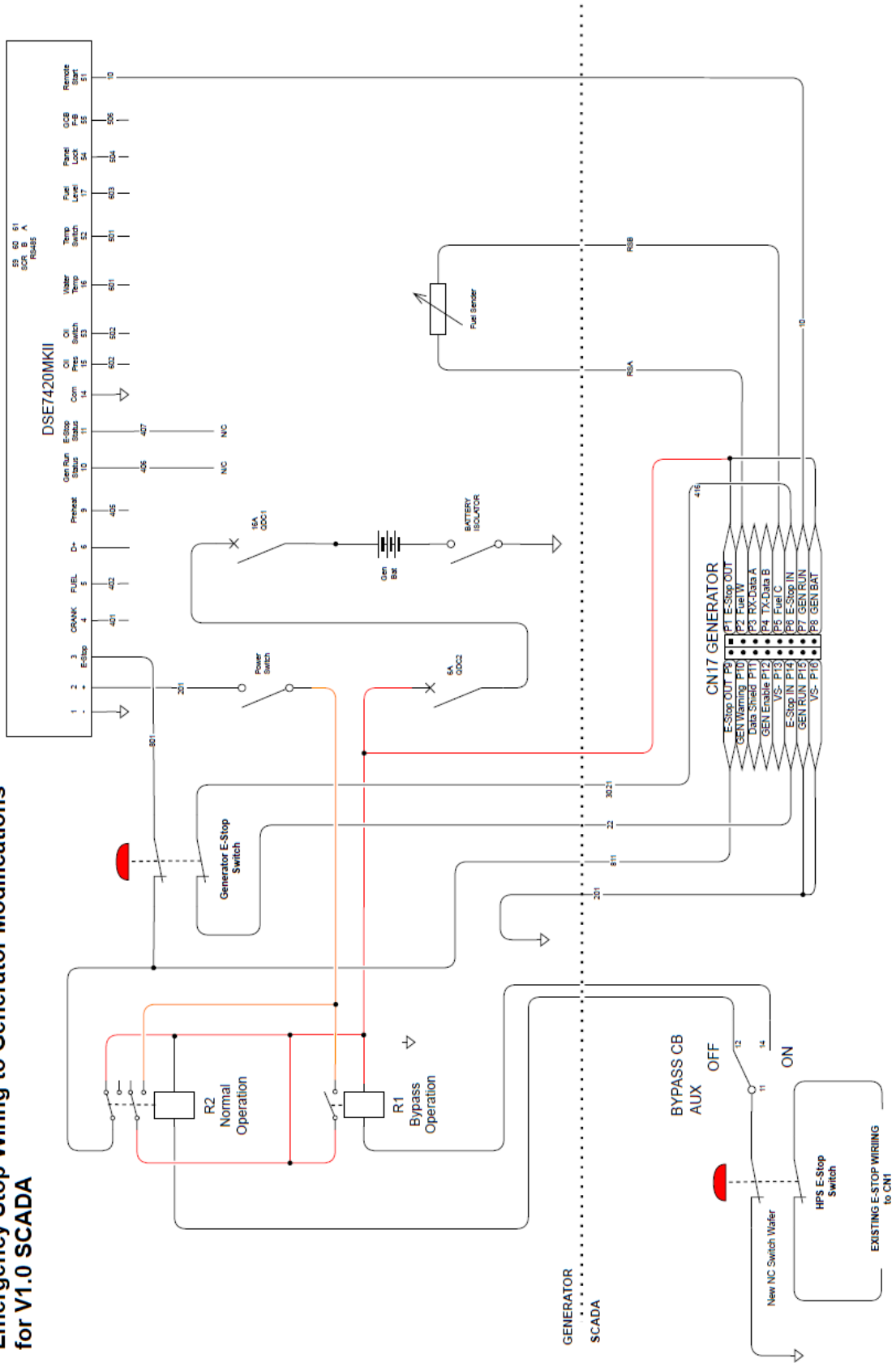

# APPENDIX B – HPS SYSTEMS LINE DIAGRAM

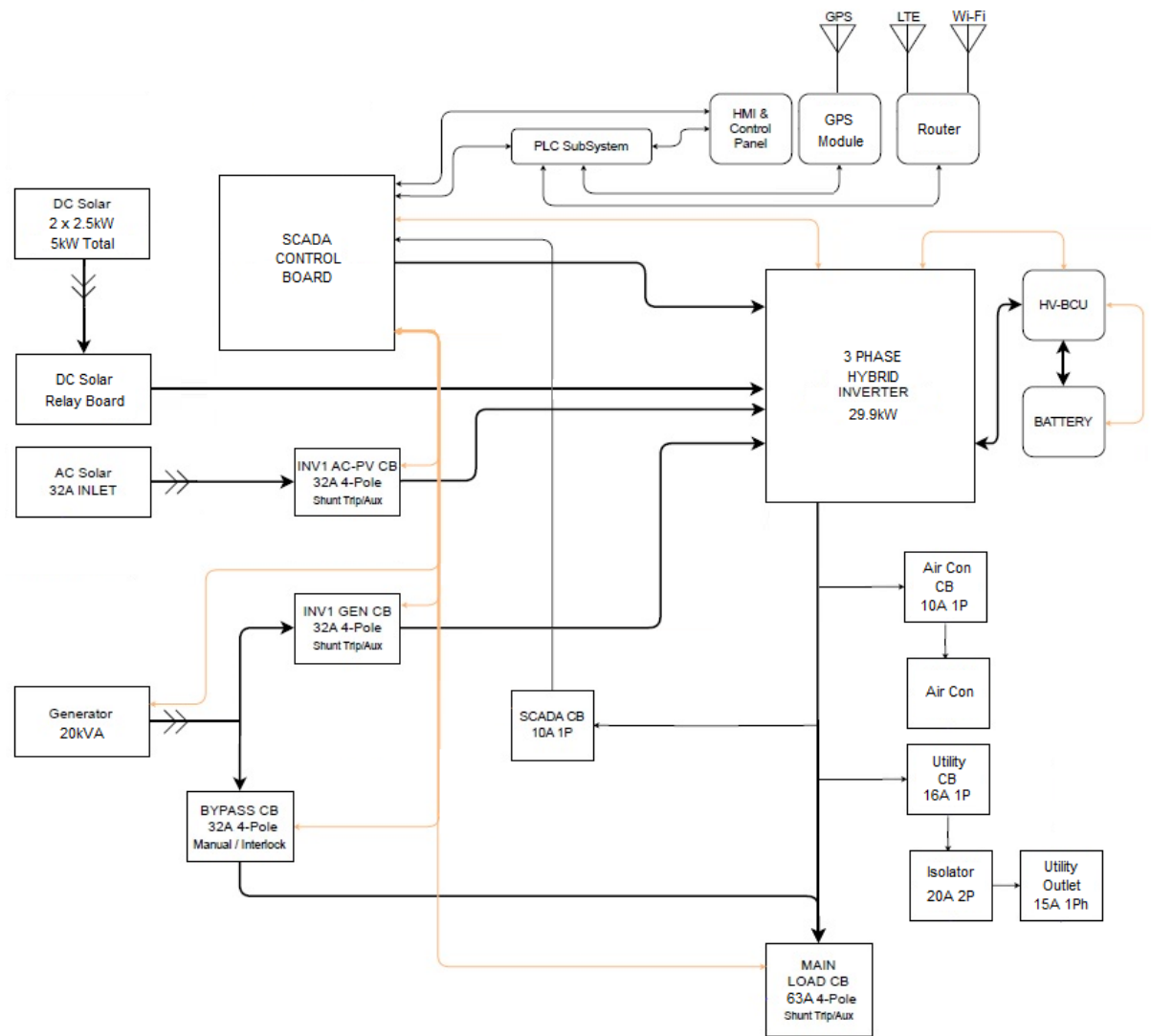

## APPENDIX C – RISK ASSESSMENT

PRODUCT RISK / HAZARD ASSESSMENT TABLE			
Product Name:	HYBRID POWER SYSTEM Serial Number: _____ Asset Number: _____	Assessment Carried Out By:	Craig Skipsey
Manufacturer:	MAKINEX Renewables Pty Ltd	Document Revision Number:	1.2
Operator Competency:	As per User Manual	Date:	19/12/2024

No:	TYPE / NATURE OF RISK or HAZARD		LIKELIHOOD	CONSEQUENCE	RISK LEVEL	CONTROL ACTION
1	<b>ENTANGLEMENT</b> Hair, clothing, gloves, etc. may become entangled in moving parts of equipment	1.1 Loose clothing, hair and rags entangled in moving parts.	4 <b>VERY UNLIKELY</b>	3 <b>MINOR</b>	3 <b>LOW</b>	Always switch the unit off before carrying out maintenance or inspections. Keep access doors closed and stand clear during operation. During electrical maintenance, the e-stop should be pressed, and the main DC isolator are to be locked out. During mechanical (generator) maintenance, the communications cable can be disconnected which places the generator in e-stop condition. Note that the buzzer alarm will sound PRIOR to the engine cranking over, should the e-stop not be pressed.
2	<b>CRUSHING</b> Due to unexpected movement, falling loads, plant collapse, contact with moving parts of equipment	2.1 Crush from plant tipping	3 <b>UNLIKELY</b>	2 <b>MAJOR</b>	2 <b>MEDIUM</b>	Ensure unit is placed on even, level surface. Ensure outriggers are always deployed during operation. Observe operator's manual recommendations for wind rating max 136km/hr or Category A & B regions.
		2.2 Crush from lifting / moving plant	3 <b>UNLIKELY</b>	2 <b>MAJOR</b>	2 <b>MEDIUM</b>	Lifting lugs to be used in accordance with the instructions provided on the lifting certificate in the operations manual. Clear area around lifting, visual contact between crane operator and others assisting with the lift. When using forklift, ensure SWL to lift 'wet weight' noted on the unit.
3	<b>CUTTING, STABBING OR PUNCTURING</b> Contact with sharp objects, contact with moving parts, disintegration or ejection of equipment parts	3.1 No Hazard	4 <b>VERY UNLIKELY</b>	3 <b>MINOR</b>	3 <b>LOW</b>	Ensure the use of gloves when operating the solar wings. Observe pinch points as per decals provided on the unit
4	<b>SHEARING</b> Between two moving parts of the equipment or between a fixed object and moving part	4.1 Pinch/Shear of body parts from contact with access doors	4 <b>VERY UNLIKELY</b>	4 <b>NEGLIGIBLE</b>	3 <b>LOW</b>	Ensure hands and limbs are clear when closing doors.
		4.2 Pinch/Shear of body parts between solar panel wings and frame	4 <b>VERY UNLIKELY</b>	3 <b>MINOR</b>	3 <b>LOW</b>	Ensure hands and limbs are clear when closing wings.

			when closing or failure of wing support							Ensure struts are correctly installed and secured
		4.3	Pinch/Shear of body parts between unit and stationary structures/items during lifting/moving	4	VERY UNLIKELY	2	MAJOR	2	MEDIUM	Lifting lugs to be used in accordance with the instructions provided on the lifting certificate in the operations manual. Clear area around lifting, visual contact between crane operator and others assisting with the lift. When using forklift, ensure SWL to lift 'wet weight' noted on the unit
5	<b>STRIKING</b> Struck due to uncontrolled movement, disintegration or ejection of equipment parts	5.1	Striking from a failure of wing support	4	VERY UNLIKELY	3	MINOR	3	LOW	Ensure struts are correctly installed and secured
6	<b>HIGH-PRESSURE FLUID</b> Contact with fluids under pressure	6.1	No Hazard							
7	<b>ELECTRICAL</b> Contact with live wires, overload of circuits, damaged or poorly maintained equipment	7.1	Electrocution due to exposed/damaged wiring	3	UNLIKELY	2	MAJOR	2	MEDIUM	Make sure connections are covered, and wiring is managed away from common operation areas. Note: All electrical connections and cables are protected by RCD's or similar AS3000 compliant protection devices. Ensure MEN link is enabled on the HPS or at the local distribution board – NOT both (as outlined in the operations manual). Electrical deployment to be carried out by a licenced electrician.  When carrying out inspection, the e-stop must be pressed.

No:	TYPE / NATURE OF RISK or HAZARD	LIKELIHOOD		CONSEQUENCE		RISK LEVEL		CONTROL ACTION		
8	<b>EXPLOSION</b> Gases, vapours, liquids, dust or other substances, triggered by the operation of the plant or by material handled by the plant	8.1	Fire or explosion when refuelling the generator	3	UNLIKELY	2	MAJOR	2	MEDIUM	Switch the unit off before refuelling, carrying out maintenance or inspections.
		8.2	Fire or explosion from damaged batteries	3	UNLIKELY	2	MAJOR	1	HIGH	Frequent inspection of batteries and connections Observe operator's manual recommendations for battery operating temperatures Avoid harsh impact and movement of the unit that may damage batteries Note: engineering controls including temperature / over/under voltage/current will de-energize the system before any fire risk occurs with the lithium battery system, inverters and other equipment in the electrical cabinet In the event of a lithium fire, immediately contact emergency services by dialling 000.
9	<b>SLIP, TRIP OR FALL</b> Poor housekeeping, obstacles, lack of work platform, poor floor surfaces	9.1	Trip Hazard walking into outriggers or deployed wings	3	UNLIKELY	4	NEGLIGIBLE	3	LOW	Use hazard tape/barriers warning of the potential hazard. Outriggers are painted yellow for improved visibility.
10	<b>ERGONOMIC</b> Poorly designed seating, repetitive body movement, poor body posture, excessive effort, poor lighting	10.1	No Hazard							
11	<b>ASPHYXIATION</b> Lack of oxygen or atmospheric contamination	11.1	Using a machine in unventilated areas	4	VERY UNLIKELY	3	MINOR	3	LOW	Do not operate machinery in confined or enclosed spaces, ensure adequate ventilation. Take note of diesel exhaust as generator can start automatically as the system requires – this is indicated on the unit.
		11.2	Toxic fumes in the event of a lithium fire	4	VERY UNLIKELY	3	MINOR	2	LOW	Lithium fires can emit toxic fumes, utilize a breathing apparatus when extinguishing fire as per firefighting instructions
12	<b>HIGH TEMPERATURE OR FIRE</b> Contact with objects at high temperature or injured by fire	12.1	Fire or explosion when refuelling	3	UNLIKELY	2	MAJOR	2	MEDIUM	Switch the unit off before refuelling, carrying out maintenance or inspections.
		12.2	Fire or explosion from damaged batteries	3	UNLIKELY	2	MAJOR	1	HIGH	Frequent inspection of batteries and connections Observe operator's manual recommendations for battery operating temperatures Avoid harsh impact and movement of the unit that may damage batteries. In the event of a lithium fire, immediately contact emergency services by dialling 000.
		12.3	Contact with hot surfaces on the generator during maintenance, service or repairs	3	UNLIKELY	2	MAJOR	2	MEDIUM	Switch the unit off and allow to cool down sufficiently before carrying out maintenance or inspections. Note: hot surface decal near exhaust outlet.
13	<b>OTHER HAZARDS</b> Chemicals - Toxic Gases, Vapours, Fumes or Dust	13.1	Damage to hearing due to long term use	4	VERY UNLIKELY	2	MAJOR	2	MEDIUM	Position station away from workers Always wear appropriate PPE

Noise - Noise levels > 85db(A). Vibration. Radiation. Other	13.2	Irritation due to contact with diesel when refuelling	4	<b>VERY UNLIKELY</b>	3	<b>MINOR</b>	3	<b>LOW</b>	Refuel in a well-ventilated area Always wear appropriate PPE
---	------	---	---	----------------------	---	--------------	---	------------	---

<p><b>NOTES:</b> &gt;THIS DOCUMENT HAS BEEN PREPARED ACCORDING TO GUIDELINES AND RECOMMENDATIONS FOUND IN:</p> <ol style="list-style-type: none"> <li>1. 'HAZPAK' PRODUCED BY THE WORK-COVER AUTHORITY AND</li> <li>2. AUSTRALIAN STANDARD, AS/NZS 3760 IN-SERVICE SAFETY INSPECTION AND TESTING OF ELECTRICAL EQUIPMENT.</li> </ol>	<p><b>"LIKELIHOOD LEVEL"</b> REFERS TO THE PROBABILITY OF AN EVENT HAPPENING. THE FOLLOWING SCALE HAS BEEN USED TO DESCRIBE THE LIKELIHOOD OF A DEFINED RISK / HAZARD EVENT OCCURRING DURING THE NORMAL OPERATION OF THE EQUIPMENT. NOTE THAT LIKELIHOOD EVALUATION IS QUALITATIVE AND BASED ON BEST ESTIMATION VIA CONSULTATION AND EXPERIENCE:</p> <ol style="list-style-type: none"> <li>1. <b>VERY LIKELY</b></li> <li>2. <b>LIKELY</b></li> <li>3. <b>UNLIKELY</b></li> <li>4. <b>VERY UNLIKELY</b></li> </ol>	<p><b>"CONSEQUENCE"</b> REFERS TO THE SEVERITY OF INJURY CAUSED DUE TO AN EVENT OCCURRING, USING THE FOLLOWING SCALE AS DEFINED BY THE "HAZPAK" DOCUMENT:</p> <ol style="list-style-type: none"> <li>1. <b>FATALITY</b> = INJURIES RESULT IN DEATH</li> <li>2. <b>MAJOR</b> = NORMALLY IRREVERSIBLE INJURIES</li> <li>3. <b>MINOR</b> = REVERSIBLE INJURIES REQUIRING SEVERAL DAYS OFF</li> <li>4. <b>NEGLIGIBLE</b> = ABLE TO BE TREATED USING FIRST AID</li> </ol>	<p><b>"RISK LEVEL"</b> REFERS TO THE SEVERITY OF A RISK-BASED ON THE "LIKELIHOOD LEVEL" AND "INJURY LEVEL".INHERENTLY, AS THE CONSEQUENCE INCREASES IN SEVERITY, RISK INCREASES - EVEN WHEN LIKELIHOOD IS LOW - THE FOLLOWING SCALE HAS BEEN USED:</p> <ol style="list-style-type: none"> <li>1. <b>HIGH</b> = POTENTIAL DEATH, PERMANENT DISABILITY, OR MAJOR STRUCTURAL DAMAGE.</li> <li>2. <b>MEDIUM</b> = POTENTIAL TEMPORARY, DISABILITY, OR MINOR STRUCTURAL DAMAGE.</li> <li>3. <b>LOW</b> = POTENTIAL INCIDENT THAT HAS THE POTENTIAL TO CAUSE PERSONS TO REQUIRE FIRST AID.</li> </ol>
--	---	--	---

**Operator Sign-off**

Name	Signature	Date



## APPENDIX D – WIND RATING CERTIFICATE

23<sup>rd</sup> June 2023

Makinex Pty Ltd  
15 Waltham Street,  
Artarmon, NSW 2064



### STRUCTURAL DESIGN CERTIFICATE FOR DEPLOYABLE SOLAR STRUCTURE

**Structure:** Makinex Deployable Solar – Skid or Trailer Mount  
**Site Address:** Australia-wide

**EXTERNAL MAXIMUM 3 SECOND GUST DESIGN WIND SPEED: 38 m/sec (136km/hr)**

We, Partridge Structural Pty Limited, being professional Structural Engineers within the meaning of the National Construction Code, hereby confirm that we have been appointed structural engineers for the above project and that the structural design of the 'Deployable Solar Structure' will be carried out under the supervision of a structural engineer certified under NER. We also confirm that this work will be designed in accordance with the relevant provisions of the Standard Building Codes, in accordance with accepted engineering practice and principles with the following:

- (a) The relevant Australian Standards listed in the NCC as follows:
- |                      |  |
|----------------------|--|
| AS/NZS 1170.0 – 2002 | Structural design actions Part 0: General principles                   |
| AS/NZS 1170.1 – 2002 | Structural design actions Part 1: Permanent, imposed and other actions |
| AS/NZS 1170.2 – 2011 | Structural design actions Part 2: Wind actions                         |
- (b) Referenced drawing numbers:  
- Drawing no. THPS-001 rev 001 dated 23.04.21, prepared by Makinex
- (c) Minimum dry weights:  
Skid frame: 1980kg with outriggers deployed 2.9m apart  
Trailer: 620kg with outriggers deployed 1.7m apart

This certificate shall not be construed as relieving any other party of their responsibilities, liabilities or contractual obligations.

Prepared by:

A handwritten signature in black ink, appearing to read 'P. Standen'.

**Peter Standen**  
BE(Hons 1) BSc MIEAust CPEng NER (Structural & Civil) RPEQ  
Managing Director

t 612 9460 9000 | Sydney Level 5, 1 Chandos Street, St Leonards NSW 2065 Australia  
t 613 7020 5300 | Melbourne Level 6, 40 City Road, Southbank VIC 3006 Australia  
e partridge@partridge.com.au | www.partridge.com.au  
Partridge Structural Pty Ltd – 73 002 451 925  
Partridge Event Pty Ltd – 50 139 601 433  
Partridge Remedial Pty Ltd – 89 145 990 521  
Partridge Hydraulic Services Pty Ltd – 11 608 027 578

2019S0460.006-ps - design certificate.docx  
Page 1 of 1

# APPENDIX E – LIFTING CERTIFICATE

28<sup>th</sup> July 2023



Makinex Pty Ltd  
15 Waltham Street,  
Artarmon, NSW 2064

**Attention: Mr Rory Kennard**

## STRUCTURAL DESIGN CERTIFICATE

Project Description: Certification of Deployable Solar Lifting Points

We, Partridge Structural Pty Limited, being professional Structural Engineers within the meaning of the National Construction Code, hereby certify that the structural design of the building work shown on the Makinex Drawing was carried out under the supervision of a structural engineer certified under NER, and that this work was designed in accordance with accepted engineering practice and principles and with the following:

- (a) National Construction Code 2022, Volume One
- (b) The relevant Australian Standards listed in the NCC as follows:

AS/NZS 1170.0 – 2002	Structural design actions Part 0: General principles
AS/NZS 1170.1 – 2002	Structural design actions Part 1: Permanent, imposed and other actions
AS 4100 – 2020	Steel structures
- (c) Attached drawings: HPS-001 HSP20-Lifting Drawing A01 & HPS-Skid Lifting Arrangement

This certificate shall not be construed as relieving any other party of their responsibilities, liabilities or contractual obligations.

**Peter Standen**  
BE (Hons1) BSc MIEAust CPEng NER (Structural & Civil)  
RPEQ RBP(EC60272)  
Managing Director

For and on behalf of:  
**Partridge Structural Pty Ltd**

t 612 9460 9000 | Sydney Level 5, 1 Chandos Street, St Leonards NSW 2065 Australia  
t 613 7020 5300 | Melbourne Level 6, 40 City Road, Southbank VIC 3006 Australia  
e partridge@partridge.com.au | www.partridge.com.au  
Partridge Structural Pty Ltd – 73 002 451 925  
Partridge Event Pty Ltd – 50 139 601 433  
Partridge Remedial Pty Ltd – 80 145 990 521  
Partridge Hydraulic Services Pty Ltd – 11 608 027 578

2019S0460.007-psg - design certificate.docx  
Page 1 of 1



**MAKINEX**  
RENEWABLES

